

DIGITAL PROPORTIONAL R/C SYSTEM

TBPV



SHORT MANUAL

This manual is a simplified version. Detailed of each function are not described.
Refer to your countries distributor website for the full manual and update
contents download.

<https://futabausa.com> (<https://www.rc.futaba.co.jp>)

1M23N40702

Futaba®



INTRODUCTION

Thank you for purchasing a Futaba F-4G 2.4GHz 6PV digital proportional R/C system. This system is extremely versatile and may be used by beginners and pros alike. In order for you to make the best use of your system and to drive safely, please read this manual carefully. If you have any difficulties while using your system, please consult the manual, our online Frequently Asked Questions (on the web pages referenced below), your hobby dealer.

Due to unforeseen changes in production procedures, the information contained in this manual is subject to change without notice.

Please note that the illustrations and screen images in this manual may differ from the actual product.

<https://futabausa.com>
(<https://www.rc.futaba.co.jp>)

Application, Export, and Modification

1. This product is only designed for use with radio control models. Use of the product described in this instruction manual is limited to radio control models.
2. Exportation precautions:
 - (a) When this product is exported, it cannot be used where prohibited by the laws governing radio waves of the destination country.
 - (b) Use of this product with other than models may be restricted by Export and Trade Control Regulations.
3. Modification, adjustment, and replacement of parts: Futaba is not responsible for unauthorized modification, adjustment, or replacement of parts on this product.

OUTSIDE NORTH AMERICA

Please contact the Futaba importer in your region of the world to assist you with any questions, problems or service needs. Please recognize that all information in this manual, and all support availability, is based upon the systems sold in North America only. Products purchased elsewhere may vary. Always contact your region's support center for assistance.

Compliance Information Statement (for U.S.A.)

This device complies with part 15 of the FCC Rules. Operation is subject to the following three conditions:

- (1) This device may not cause harmful interference, and (2) This device must accept any interference received, including interference that may cause undesired operation.
- (3) RF Radiation Exposure Statement (For T6PV)

This equipment complies with FCC radiation exposure limits set forth for an uncontrolled environment. This transmitter must not be co-located or operating in conjunction with any other antenna or transmitter.

RF Radiation Exposure Statement (For R404SBS / R404SBS-E)

This equipment complies with FCC radiation exposure limits set forth for an uncontrolled environment. This equipment should be installed and operated with minimum distance 20cm between the radio and your body.

The responsible party for the compliance of this device is:

Futaba Service Center
2681 Wall Triana Hwy Huntsville, AL 35824, U.S.A.
TEL 1-256-461-9399 or E-mail: contactus@futaba.com

CAUTION:

To assure continued FCC compliance:

Any changes or modifications not expressly approved by the grantee of this device could void the user's authority to operate the equipment.

Compliance Information Statement (for Canada)

This device complies with Industry Canada license-exempt RSS standard(s). Operation is subject to the following two conditions: (1) this device may not cause interference, and (2) this device must accept any interference, including interference that may cause undesired operation of the device. This equipment complies with IC radiation exposure limits set forth for an uncontrolled environment. This transmitter must not be co-located or operating in conjunction with any other antenna or transmitter.

French: Cet appareil radio est conforme au CNR-247 d'Industrie Canada. L'utilisation de ce dispositif est autorisée seulement aux deux conditions suivantes : (1) il ne doit pas produire de brouillage, et (2) l'utilisateur du dispositif doit être prêt à accepter tout brouillage radioélectrique reçu, même si ce brouillage est susceptible de compromettre le fonctionnement du dispositif. Cet équipement est conforme aux limites d'exposition aux rayonnements IC établies pour un environnement non contrôlé.

Cet équipement est conforme aux limites d'exposition aux rayonnements IC établies pour un environnement non contrôlé. Cet émetteur ne doit pas être co-situé ou fonctionner conjointement avec une autre antenne ou émetteur.

Declaration of Conformity (for EU)

Hereby, Futaba Corporation declares that the radio equipment type is in compliance with Directive 2014/53/EU.

The full text of the EU declaration of conformity is available at the following internet address:

<https://www.rc.futaba.co.jp/english/dl/declarations.html>

Table Of Contents

T6PV



● Safety Precautions	4	● Optional carbon handle	15
● Explanation Of Symbols	4	● Battery Replacement Method	16
● 2.4GHz System Precautions	4	● Low Battery Alarm	16
● Receiver Mode Precautions	4	● When Using The Optional Battery	17
● Operation Precautions	5	● Optional NiMH LiFe Battery Replacement Method	17
● Option Battery Handling Precautions	5	● Optional LiPo Battery LT2F2000B Replacement Method	18
● Storage And Disposal Precautions	6	● When Charging For The Optional LiPo Battery	18
● Other Precautions	6	● Steering Wheel Arrangement	19
● Features	7	● Exchange procedure to wheel adaptor 32 deg and large diameter wheel	20
● Set Contents	8	● Installing the accessory APA steering wheel offset adapter	21
● Specifications	8	● Angle Spacer	23
● Transmitter T6PV Nomenclature	9	● Trigger Brake Lever Replacement	24
● Power & Display Switch	10	● Handling The Antenna	24
● Display When Power Switch Is Turned On	10	● Receiver Terminology	25
● Power Off Forgotten Alarm & Auto Power Off	11	● Receiver Installation	25
● Steering Wheel And Throttle Trigger Operation	11	● Receiver and Servo Connections	26
● Digital Trim Operation	12	● Installation Safety Precautions	27
● Trim/Dial Lock	13	● Menu Selection	29
● Mechanical ATL Adjustment	13	● Jog key/DIR/END Button	30
● Wheel & Trigger Tension Adjustment	14	● Value Of Each Function And Changing The Set Value	31
● Trigger Slide Adjustment	14	● Linking Method For F-4G System	32
● SW: Push switch DL: Dial	15		
● Optional Grip Rubber	15		



Use this product in a safe manner. Please observe the following safety precautions at all times.

Explanation Of Symbols

For safety's sake, pay special attention whenever you see the marks shown here.



For safe use

 Danger	Procedures which may lead to dangerous conditions and cause death/serious injury if not carried out properly.
 Warning	Procedures which may lead to a dangerous condition or cause death or serious injury to the user if not carried out properly, or procedures where the probability of superficial injury or physical damage is high.
 Caution	Procedures where the possibility of serious injury to the user is small, but there is a danger of injury, or physical damage, if not carried out properly

Symbols:  : Prohibited  : Mandatory











2.4GHz System Precautions

Warning

-  Special attention should be paid before turning on the system while other cars are running or other airplanes are flying because the 2.4GHz RC system could potentially affect them.
-  Be sure to set the Fail-safe function.

Receiver Servo Mode Precautions

Caution

-  **Be sure to match the operation mode for both the servos and transmitter.**
-
- Please adjust the receiver settings on the transmitter according to the servo you are using and its operating mode (UR/SR/digital/analog). (For each channel) If the settings are not correct, it may damage the servo, battery, etc.. Please use Futaba genuine products as Futaba won't cover the damage caused by using other brand servos or peripherals such as extension cable, etc..
-  For servos for which the operation mode can be set, change the servo operation mode according to the system to be used. If the operating modes of the system and servo are different, it will fail.
 -  Use UR servo (Set to UR mode) for UR mode. Use SR servo (Set to SR mode) for SR mode.
 -  When the UR(SR) mode is ON, it is exclusively for our UR(SR) compatible servo. Using a servo other than the UR(SR) compatible servo may cause the servo or receiver to malfunction.
 -  If a normal servo is connected to a CH with UR/SR mode ON, there is a risk of damage.
 -  Do not connect UR/SR servo (set to UR/SR mode) and analog servo in digital servo mode.
 -  Do not connect UR/SR servo (set to UR/SR mode) in analog servo mode.
 -  UR/SR servo can be used with digital or analog mode of the transmitter when the servo set to "normal" mode.
 -  Connecting an UR/SR mode compatible servo set to UR/SR mode to the S (S.BUS2 port) may cause malfunction of the servo or receiver.
 -  Receiver battery: Matched to the ratings of the receiver and connected servo (dry cell battery cannot be used).
 -  Fail-safe Unit cannot be used because the system is different. Use the fail-safe function of the transmitter.

Operation Precautions

⚠Warning

⊘ Do not operate outdoors on rainy days, run through puddles of water or use when visibility is limited.

Should any type of moisture (water or snow) enter any component of the system, erratic operation and loss of control may occur.

⊘ Do not operate in the following places.

- Near other sites where other radio control activity may occur.
- Near people or roads.
- On any pond when passenger boats are present.
- Near high tension power lines or communication broadcasting antennas.

Interference could cause loss of control. Improper installation of your Radio Control System in your model could result in serious injury.

⊘ Do not operate this R/C system when you are tired, not feeling well or under the influence of alcohol or drugs.

Your judgment is impaired and could result in a dangerous situation that may cause serious injury to yourself as well as others.

⊘ Do not touch the engine, motor, speed control or any part of the model that will generate heat while the model is operating or immediately after its use.

These parts may be very hot and can cause serious burns.

🔧 Always perform an operating range check prior to use.

Problems with the radio control system as well as improper installation in a model could cause loss of control.

(Simple range test method)

Have a friend hold the model, or clamp it down or place it where the wheels or prop cannot come in contact with any object. Walk away and check to see if the servos follow the movement of the controls on the transmitter. Should you notice any abnormal operation, do not operate the model. Also check to be sure the model memory matches the model in use.

🔧 Turning on the power switches.

Always check the throttle trigger on the transmitter to be sure it is at the neutral position.

1. Turn on the transmitter power switch.
2. Turn on the receiver or speed control power switch.

Turning off the power switches

Always be sure the engine is not running or the motor is stopped.

1. Turn off the receiver or speed control power switch.
2. Then turn off the transmitter power switch.

If the power switches are turned off in the opposite order, the model may unexpectedly run out of control and cause a very dangerous situation.

🔧 When making adjustments to the model, do so with the engine not running or the motor disconnected.

You may unexpectedly lose control and create a dangerous situation.

🔧 Before running (cruising), check the fail-safe function.

Check Method;

Before starting the engine, check the fail-safe function as follows:

- 1) Turn on the transmitter and receiver power switches.
- 2) Wait at least one minute, then turn off the transmitter power switch. (The transmitter automatically transfers the fail-safe data to the receiver every minute.)
- 3) Check if the fail-safe function moves the servos to the preset position when reception fails.

The fail-safe function is a safety feature that minimizes set damage by moving the servos to a preset position when reception fails. However, if set to a dangerous position, it has the opposite effect. When the reverse function was used to change the operating direction of a servo, the fail-safe function must be reset.
Setting example: Throttle idle or brake position

Option Battery and charger Handling Precautions

⚠Warning

⊘ Never plug the charger into an outlet of other than the indicated voltage.

Plugging the charger into the wrong outlet could result in an explosion or fire.

⊘ Never insert or remove the charger while your hands are wet.

You may get an electric shock.

⊘ Do not use the T6PV transmitter's battery as the receiver's battery.

Since the transmitter's battery has an overload protection circuit, the output power will be shut down when the high current load is applied. This may result in runaway or fatal crash.

🔧 Always check to be sure your batteries have been charged prior to operating the model.

Should the battery go empty while the model is operating, loss of control will occur and create a very dangerous situation.

🔧 To recharge the transmitter battery, use the special charger made for this purpose.

Overcharging could cause the battery to overheat, leak or explode. This may lead to fire, burns, loss of sight and many other types of injuries.

⚠ Caution

⊘ Do not use commercial AA size NiCd and NiMH batteries.

May cause the battery contacts to overheat and damage the battery holder.

⊗ **Do not short circuit the battery terminals.**

A short circuit across the battery terminals may cause abnormal heating, fire and burns.

⊗ **Do not drop the battery or expose it to strong shocks or vibrations.**

The battery may short circuit and overheat; electrolyte may leak out and cause burns or chemical damage.

ⓘ **When the model is not being used, always remove or disconnect the battery.**

Leaving the battery connected could create a dangerous situation if someone accidentally turns on the receiver power switch. Loss of control could occur.

ⓘ **Always keep the charger disconnected from the outlet while it is not in use.**

Storage And Disposal Precautions

⚠ Warning

⊗ **Do not leave the radio system or models within the reach of small children.**

A small child may accidentally operate the system. This could cause a dangerous situation and injuries. Batteries can be very dangerous when mishandled and cause chemical damage.

⊗ **Do not throw batteries into a fire. Do not expose batteries to extreme heat. Also do not disassemble or modify a battery pack.**

Overheating and breakage will cause the electrolyte to leak from the cells and cause skin burns, loss of sight, and other injuries.

ⓘ **When the system will not be used for any length of time, store the system with NiMH batteries in a discharged state. Be sure to recharge the batteries prior to the next time the system is used.**

If the batteries are repeatedly recharged in a slightly discharged state, the memory effect of the NiMH battery may considerably reduce the capacity. A reduction in operating time will occur even when the batteries are charged for the recommended time. (After discharge to 1cell E.V.=1 V)

ⓘ **When a LiFe/LiPo battery pack will not be used for a long time, to prevent it from deteriorating we recommend that it be kept in about the half capacity state instead of fully charged. Also be careful that the battery does not enter the over-discharged state due to self-discharge. Periodically (about every 3 months) charge the battery.**

⚠ Warning

⊗ **Do not store your R/C system in the following places.**

- Where it is extremely hot or cold. [Storage temperature range -10°C to +40°C]
- Where the system will be exposed to direct sunlight.
- Where the humidity is high.
- Where vibration is prevalent.
- Where dust is prevalent.
- Where the system would be exposed to steam and condensation.

Storing your R/C system under adverse conditions could cause deformation and numerous problems with operation.

ⓘ **If the system will not be used for a long period of time, remove the batteries from the transmitter and model and store in a cool, dry place.**

If the batteries are left in the transmitter, electrolyte may leak and damage the transmitter. This applies to the model also. Remove the batteries from it also to prevent damage.

<NiMH Battery Electrolyte>

The electrolyte in NiMH batteries is a strong alkali. Should you get even the smallest amount of the electrolyte in your eyes, DO NOT RUB. Wash immediately with water, and seek medical attention at once. The electrolyte can cause blindness. If electrolyte comes in contact with your skin or clothes, wash with water immediately.

<Battery Recycling>

A used battery is a valuable resource. Insulate the battery terminals and dispose of the battery by taking it to a battery recycling center.

Other Precautions

⚠ Caution

⊗ **Do not expose plastic parts to fuel, motor spray, waste oil or exhaust.**

The fuel, motor spray, waste oil and exhaust will penetrate and damage the plastic.

ⓘ **Always use only genuine Futaba transmitters, receivers, servos, ESCs (electronic speed controller), Batteries and other optional accessories.**

Futaba will not be responsible for problems caused by the use of other than genuine Futaba parts. Use the parts specified in the instruction manual and catalog.

Features

-Full color screen LCD

T6PV has a 3.2 inch, full-color, backlit LCD screen.

-F-4G system & telemetry

Equipped with an F-4G system that enables telemetry with faster response than the T-FHSS SR system.

-UR(Ultra response) mode

Equipped with UR mode that provides even better response than the SR mode. UR servo is required to use UR mode.

-6 channels

Up to 6 channels can be operated by using the S.BUS2 system together.

-MINI-Z system

By setting to the MINI-Z system in the receiver setting menu, you can use Kyosho MINI-Z. Compatible MINI-Zs vary depending on the system.

-Updateable software

Software can be updated by microSD card. Model data can also be saved in a microSD card.

-Model memory for 40 models

Model names can use up to 15 letters, numbers, and symbols, so that logical names may be used. A model memory with different setups can be created by using the model copy function.

-LiFe/LiPo battery can be used

The optional LiFe/ LiPo battery can be used as the transmitter power supply. The running time is extended.

-Response adjustment

If the response is too quick, can mild it.

-Model type

Change the initial settings to suit three types: normal, 1/5 big car, and drift.

-Brake mixing for large cars

Brake mixing of the front and rear wheels of 1/5GP and other large cars can be adjusted independently.

-Steering mixing

Smooth cornering is possible by the independent left and right steering servo setting.

-4WS mixing for crawlers and other 4WS type

This function can be used with crawlers and other 4-wheel steering type vehicles.

-Dual ESCs mixing for crawlers

ESC at the front and rear are controlled independently.

-Gyro mixing

The sensitivity of Futaba car rate gyros can be adjusted from the T6PV.

-CPS mixing

LED lighting and flashing control using our CPS-1 channel power switch can be matched to steering and throttle operation by switch only.

-Tank mixing

This function is intended for vehicles such as tanks.

-Winch mixing

Winch mixing uses a winch and applies bidirectional mixing from the throttle to winch and from the winch to throttle so that the rock crawler and winch can operate simultaneously with one input.

-Drag racing

This function can be used in a drag racing situation, where the driver can use the trans-brake to assist in the staging process.

-Updating receiver

When update software is released for the receiver, can update it by inserting the microSD card with the update software copied onto it into the transmitter and connecting the receiver to the transmitter.

-S.BUS servo

This is a special function that allows setting of the parameters of our S.BUS servo whose settings are changed by using PC Link software.

-MC-Link

This is a dedicated function which allows setting of the contents of the Link software which makes possible Futaba electronic speed controller (ESC), MC971CR/ MC970CR. variable frequency and other data changes by PC at the T6PV.

-Gyro-Link

This function allows you to change the parameters of our car gyro wirelessly from the T6PV main unit.
* Compatible gyro: GYD550 (as of November 2024)

-Throttle speed

Sudden trigger operation on a slippery road surface will only cause the tires to spin and the model to not accelerate smoothly. By setting the throttle speed function, operation can be performed smoothly and easily. It also suppresses battery consumption.

-Steering speed

When you sense that the steering servo is too fast, etc., the servo operating speed (direction that suppresses the maximum speed) can be adjusted.

-Dial select function

This function assigns functions to dials. The step amount and operating direction can also be adjusted. Trim positioning at each model call is unnecessary because all the dials are digital.

-Switch select function

This function assigns functions to 3 switches. The operating direction can also be set.

-Wheel & Trigger position can be changed

The wheel position can be offset by using an accessory APA wheel position offset adapter.

The wheel angle can also be adjusted.

The position of the throttle trigger can be moved forward and backward.

-Trim/dial lock functions

Lock functions which prohibit setting and operation by transmitter trim, and dials are provided.

-Function icon display

Each function is displayed as an easy-to-see icon.

Set Contents

After opening the box, first check if the contents conform to the following. The contents depend on the set as shown below.

Transmitter / Receiver	T6PV / R404SBS or R404SBS-E * Some sets do not include a receiver/servo. The contents of the set vary depending on the order.
Miscellaneous	Wheel offset adapter-M size(APA) APA Mounting screws *Spare screws are also included Wheel adapter 32 deg Brake lever L Wheel Angle spacer 5 deg Large diameter steering wheel UR/SR label Short manual Hex wrench

- If any of the set contents are missing, or you have any questions, please contact your dealer.

⊘ The R404SBS-E receiver is for electric. Do not use for the gas powered models.

! Always use only genuine Futaba transmitters, receivers, servos, ESCs (electronic speed controls), batteries and other optional accessories.

Futaba will not be responsible for problems caused by the use of other than Futaba genuine parts. Use the parts specified in the instruction manual and catalog.

In addition, the Fail-safe Unit cannot be used because the system is different. Use the fail-safe function of the transmitter.

Specifications

Transmitter T6PV

*Specifications and ratings are subject to change without prior notice.

- Wheel system, 6 channels (F-4G System), 6 channels (S-FHSS System), 4 channels (T-FHSS systems)
- Transmitting frequencies 2.4GHz band /- Transmitting RF power output: 100 mW EIRP
- Futaba F-4G/T-FHSS/S-FHSS/MINI-Z EVO/MINI-Z EVO2/MINI-Z FHSS systems
- Transmitting antenna 1/2λdipole
- 3.2 inch backlight color display.

Receiver R404SBS / R404SBS-E

- Receiving frequency: 2.4GHz band /- Telemetry Receiver RF power output: R404SBS: 1.02 mW EIRP R404SBS-E: 2.2 mW EIRP
- Power requirement: 3.7 V~7.4 V battery (Dry cell battery cannot be used.)
- System: F-4G system/S.BUS2 system
- Size: R404SBS---1.00x0.81x0.42" 25.5x20.7x10.6 mm
 R404SBS-E---1.00x0.81x0.42"(include antenna 1.20") 25.5x20.7x10.6 mm(include antenna 30.5 mm)
- Weight : R404SBS---0.2 oz. (5.7 g) / R404SBS-E---0.25 oz. (7.2 g)

Transmitter T6PV

Nomenclature

- *The switches, dial, and trimmers in the figure are shown in the initial setting position.
- *Please be careful not to push the switch too strongly.

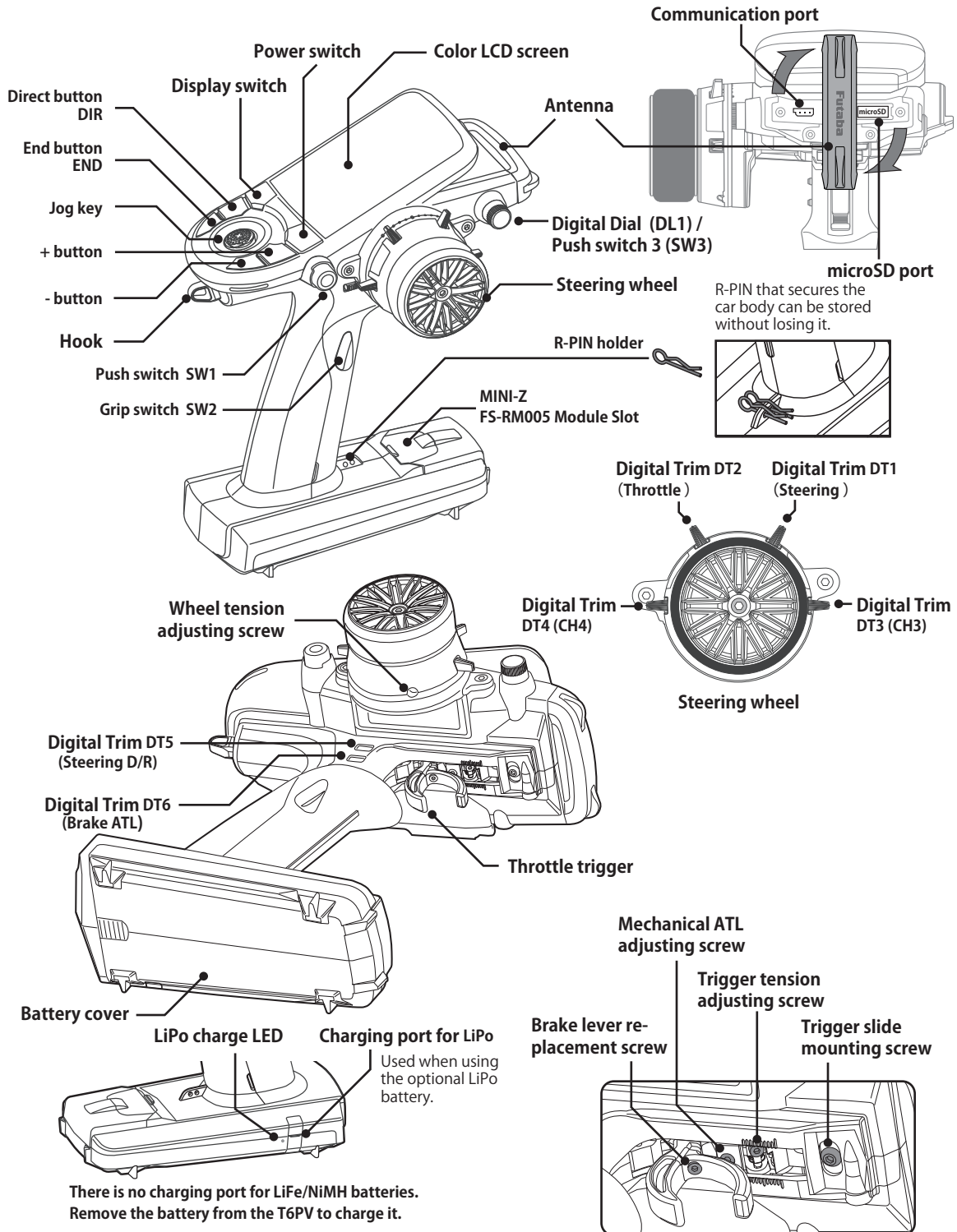

Power & Display Switch

The power switch and display switch are push switches.

When the power switch (PWR) is held down, operation starts by transmitting radio waves. When the display switch (DSP) is held down, the transmitter side data can be checked and set. When the power is turned off, if the power switch or display switch is held down, the power is turned off. If both switches are pressed simultaneously, the power is turned off quickly.

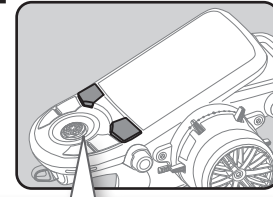

Power & Display Switch

"Display mode" is shown.

Radio waves are not being transmitted.

It cannot operate.

OFF

When the power is turned off, if the power switch or display switch is held down, the power is turned off. If both switches are pressed simultaneously, the power is turned off quickly.

Please turn off if not in use.

PWR

Radio waves are being transmitted.

It can operate.

Display When Power Switch Is Turned On

The current system is shown. When turned on by DSP switch, "Display" is indicated.

Labels and descriptions:

- Total timer: 1:21
- Transmitter Battery voltage display: 6.3V
- Model name (15 characters): F-4G Model 1
- Trim/dial lock display mark: TRIM LOCK
- microSD card mark: [MicroSD icon]
- Upper: Steering trim display: ST Trim
- Lower: Throttle trim display: TH Trim
- Receiving signal strength of control signal: Rx
- Receiver battery voltage: ---
- Functions and rate assigned to each trims/dials:

DT1 Steering trim	0
DT2 Throttle trim	0
DT3 Channel 3 control	+0
DT4 Channel 4 control	+0
DT5 Dual rate	+100
DT6 Brake1 rate(ATL)	+100
DL1 Off	

*The figure above is partly processed for explanation, so it is different from the actual screen display.

Power Off Forgotten Alarm & Auto Power Off

When leave the transmitter without any operation of steering wheel, throttle trigger, push switch, edit button, or other operation 10 minutes, the audible alarm will sound and the message "Warning: Auto power off" will appear. If any operation given within 5 minutes from the warning the alarm is reset. On the other hand, If the operation is not given in 5 minutes, the power will be automatically shut down. If you want to disable this alarm and the auto power off function, they can be set by System menu--Battery setting. (Refer to country distributor WEB for detailed explanation.)

Low Battery Alarm

If the transmitter battery voltage drops below the usable range, an audible alarm will sound and "Low battery" will appear on the display. Since the usable range of Dry cell battery/NiMH/LiFe and LiPo batteries is different, the battery type using must be set by System menu → Battery. (Refer to country distributor WEB for detailed explanation.)

Warning

! When a low battery alarm is generated, cease operation immediately and retrieve the model. Always replace with a new dry battery before running next.

If the battery goes empty while in operation, you will lose control of the model.

Steering Wheel And Throttle Trigger Operation

(CH1: Steering wheel, CH2: Throttle trigger)

Steering Wheel Function: Turns the model right or left.

Throttle Trigger Function: Controls the speed of the model as well as the direction of travel - forward or reverse.

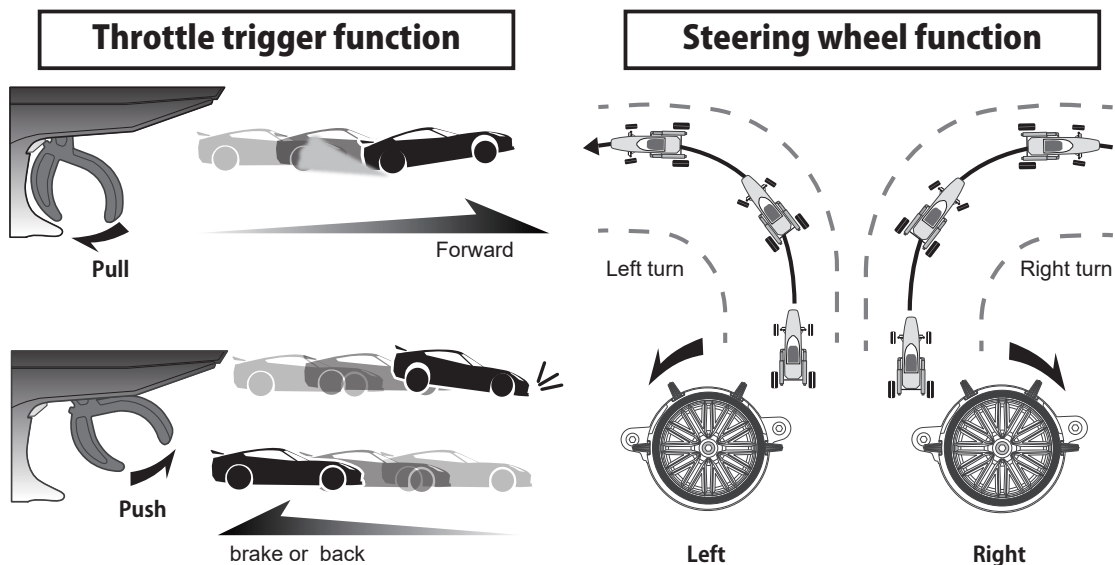

Digital Trim Operation

(Initial settings: DT1: Steering trim, DT2: Throttle trim, DT3: Channel 3, DT4: Channel 4, DT5: Steering D/R, DT6: ATL-Brake rate)

Operating by the trim: Push the trim lever to the left or right (up or down). The current position is displayed on the LCD screen.

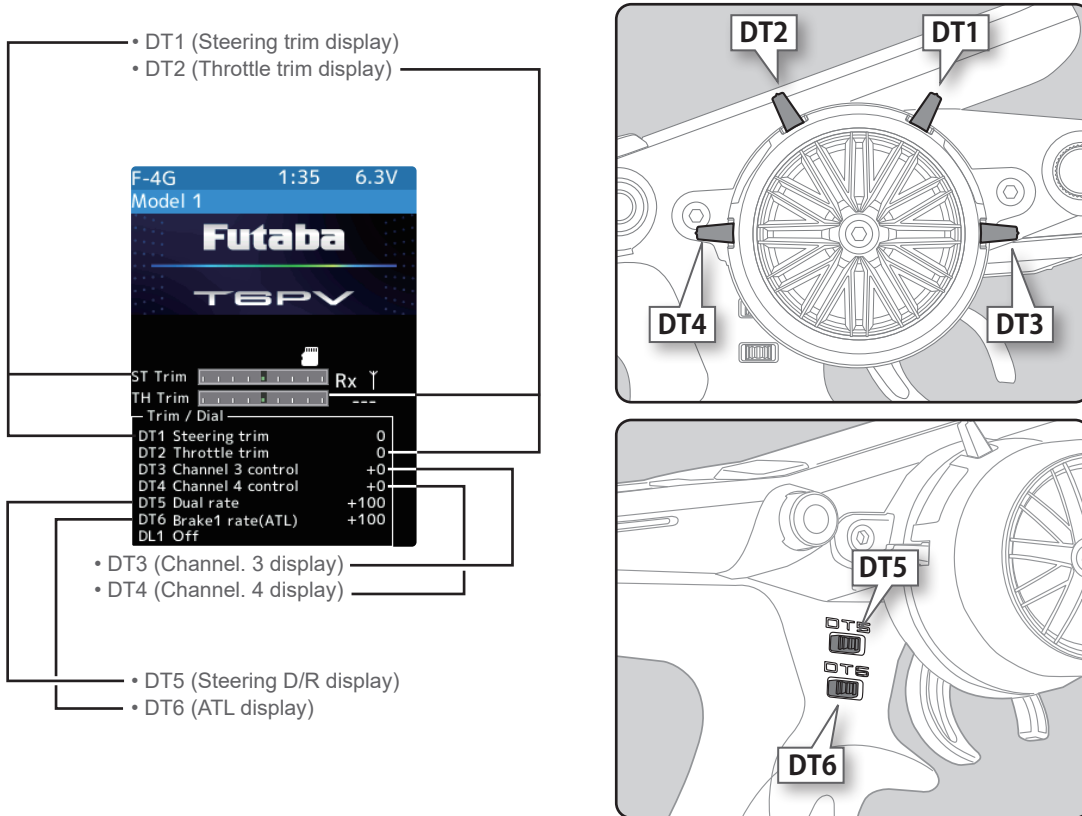

- Each step is indicated by a tone.
- When the trim exceeds the maximum trim adjustment range, the beep will change and the servo will not move any farther.
- When the steering wheel is neutral, adjust the steering trim so that the car goes straight without curving left and right.
- Adjust the throttle trim so that the car stops when the throttle trigger is in neutral so that the brake will not be applied when the throttle trigger is released during operation.
- Steering D/R :The steering left and right servo travels are adjusted simultaneously.
- ATL: Decreases the set value when the braking effect is strong and increases the set value when the braking effect is weak.

Steering And Throttle Trim Operation

With the center trim feature, trim adjustments have no effect on the maximum servo travel. This prevents the linkages from binding when adjustments are made.

Trim/Dial Lock

T6PV setup and operation by digital trim DT1, DT2, DT3, DT4, DT5 and DT6 and dials DL1 can be prohibited.

Setting

- 1 When the END button is pressed for about 1 second on the initial screen, a confirmation beep sounds and the trim/dial lock sign appears on the screen.

Clearing

- 1 Edit button lock and trim/dial lock can be cleared in the initial screen state by the same method as the setting described above. (The trim/dial lock sign disappears from the screen.)

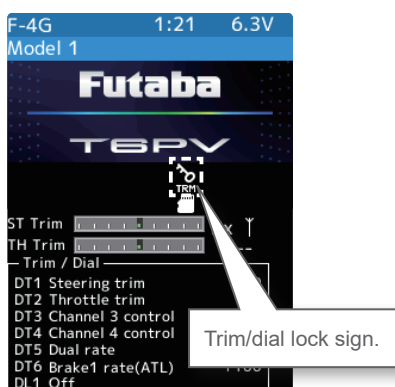

Mechanical ATL Adjustment

Make this adjustment when you want to decrease the stroke of the brake (back) side of the throttle trigger for operation feel.

Adjustment

- 1 Using a hex wrench, adjust the trigger brake (reverse) stroke. (The screw moves the throttle trigger stopper.)

- Adjust the stroke while watching the screw.

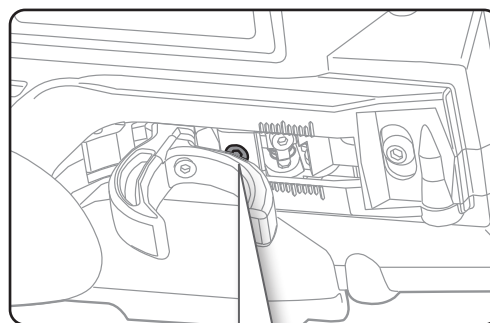

Note:

Once you have changed the mechanical stroke on the brake side, be sure to adjust the scale of the throttle channel accordingly by using the "Calibration Function (System menu)". (Refer to country distributor WEB for detailed explanation.)

Due to this change, you also need to adjust in most cases the travel of the throttle servo.

Wheel & Trigger Tension Adjustment

Make this adjustment when you want to change the wheel or trigger spring's tension.

Adjustment

- 1 Using hex wrench, adjust the wheel spring tension by turning the screw inside the adjusting hole.
 - The spring is set to the weakest tension at the factory.
 - When the adjusting screw is turned clockwise, the spring tension increases.

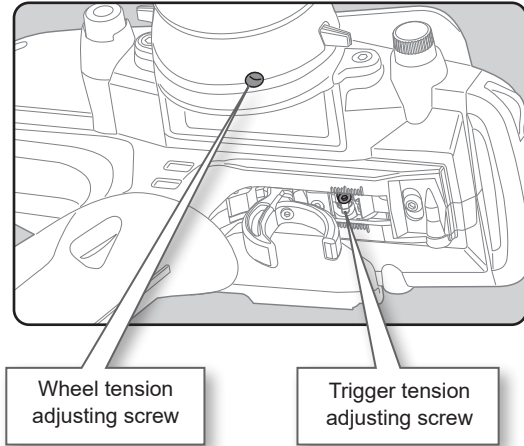

Note:

The adjustment range is up to 7 to 8 turns from the fully tightened (strongest) position. If turned farther than this, the adjusting screw may fall out.

Trigger Slide Adjustment

The throttle trigger position can be moved forward and backward.

Adjustment

- 1 Using a hex wrench, loosen the trigger slide mounting screw by turning it slightly counterclockwise.
- 2 Adjust the trigger slide position within the marked range.
- 3 Retighten the mounting screw loosened at step 1 and fasten the trigger slide.

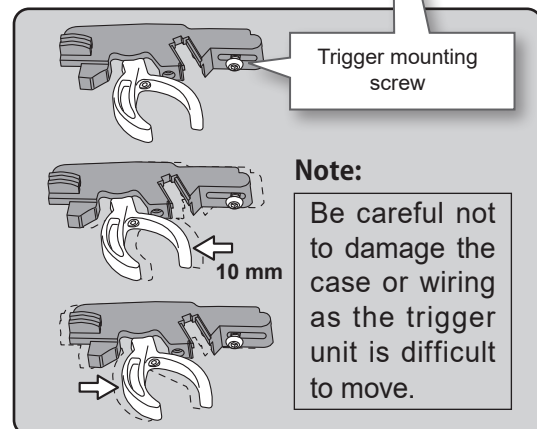
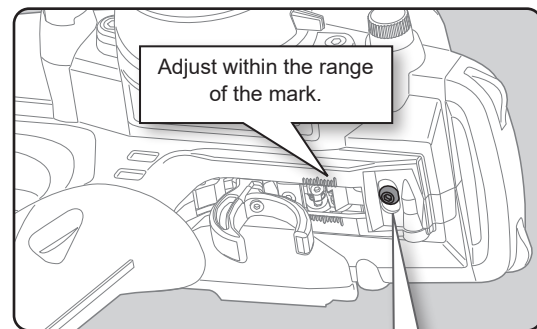

SW: Push switch DL: Dial

The position of various switches. The assignment of each function can be changed for T6PV.

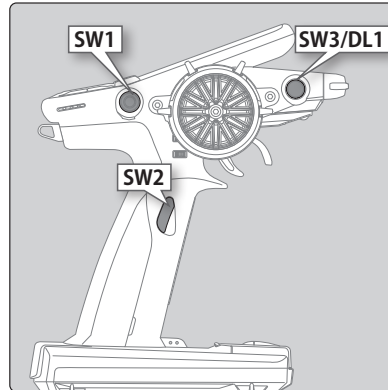

Optional Grip Rubber

Change the thickness of the grip by replacing it with the optional grip rubber for the T10PX.

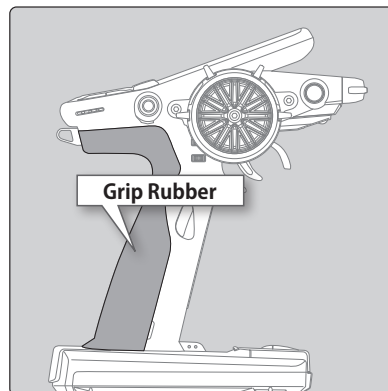

Optional carbon handle

An optional carbon handle (for T10PX/T7PX/T4PM) can be installed.

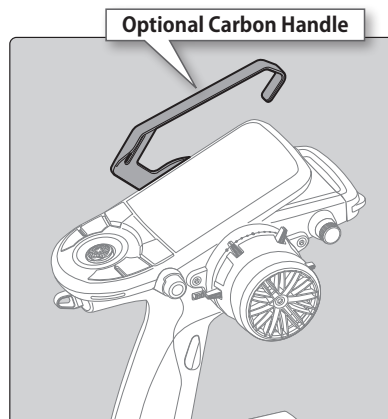

Battery Replacement Method

Load the four batteries in accordance with the polarity markings on the battery holder.

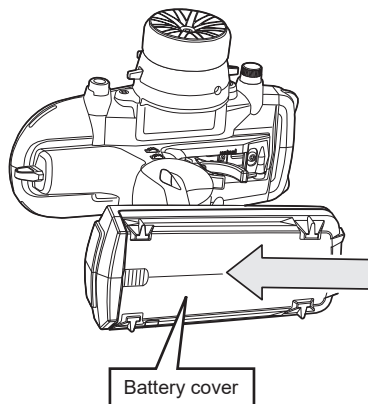
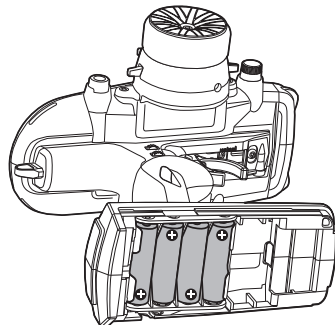
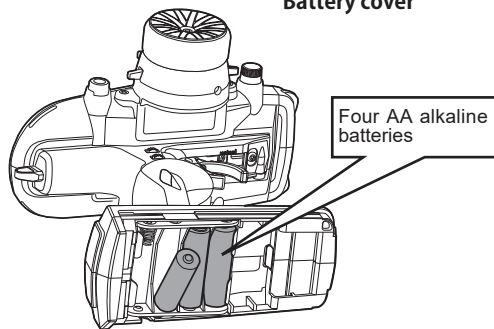
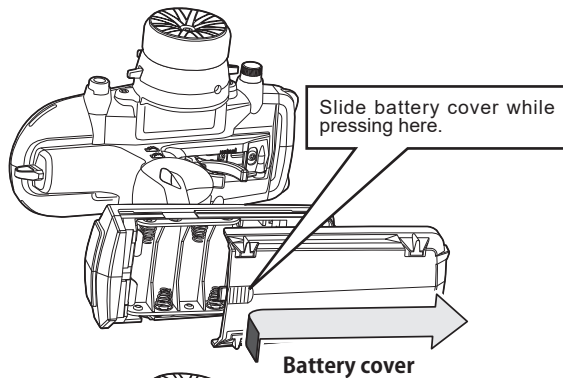

Battery Replacement Method

1 Remove the battery cover from the transmitter by sliding it in the direction of the arrow in the figure.

2 Remove the used batteries.

⚠ Caution

❗ If you remove the dry cell battery box from the transmitter, replace it carefully with the wiring on the same side as before. Reinstalling the battery box in the opposite direction could cause the wires to be disconnected.

3 Load the new AA size batteries. Pay very close attention to the polarity markings and reinsert accordingly.

4 Slide the battery cover back onto the case.

Disposal of the Dry Cell Batteries:

The method to dispose of used dry cell batteries depends on the area in which you reside. Dispose of the batteries in accordance with the regulations for your area.

Low Battery Alarm

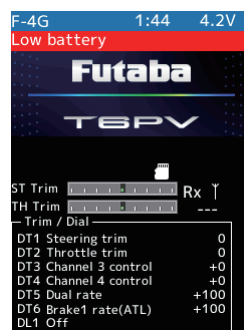

If the transmitter battery voltage drops below the usable range, the audible alarm will sound and "Low battery" will appear on the display. Since the usable range of dry battery/NiMH/LiFe batteries and LiPo batteries is different, the battery type using must be set by system setting. If the battery goes empty while running (cruising), please immediately recover the vehicle (boat) and stop running (cruising) as there is the risk of collision or no way to get the boat back.

⚠ Warning

❗ When a low battery alarm is generated, cease operation immediately and retrieve the model.

If the battery goes empty while operation, you will completely lose the control.

When Using The Optional Battery

- When using an optional rechargeable battery, replace the battery as described below.
- Always use the optional FT2F1100B(V2), FT2F1700B(V2), FT2F2100B, HT5F1800 or LT-2F2000B rechargeable battery. *Products for Europe cannot use NiMH / LiFe batteries.
 - The type of battery used must be selected through the system setting.
 - When the transmitter will not be used for a long time, remove the battery.

NiMH LiFe Battery Replacement Method

1 Remove the transmitter battery cover.

2 After removing the dry cell battery box from the transmitter, disconnect the connector.

⚠ Caution

❗ If you remove the dry cell battery box from the transmitter, replace it carefully with the wiring on the same side as before. Reinstalling the battery box in the opposite direction could cause the wires to be disconnected.

3 Insert the connector of the new battery and load the new battery into the transmitter.



Change the battery type, be sure to change the [Battery type] setting.

Change to a LiFe/NiMH battery, go to [System menu] → [Battery] and change it to [Battery type] → **LiFe 2cells/NiMH 5cells**



When charging a LiFe/NiMH battery.

Be sure to remove the battery from the transmitter, disconnect the connector, and then charge it.

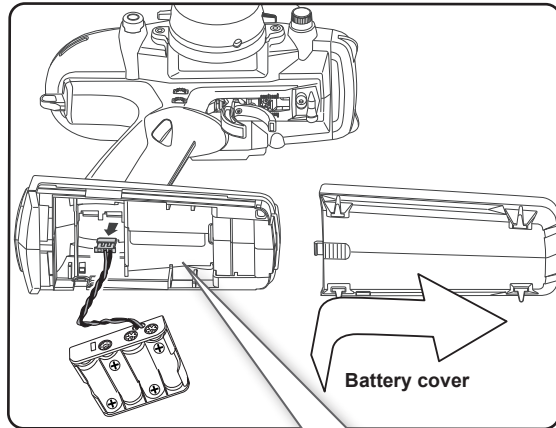

Remove the battery box and disconnect the connector.

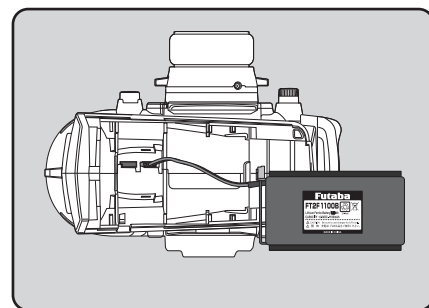
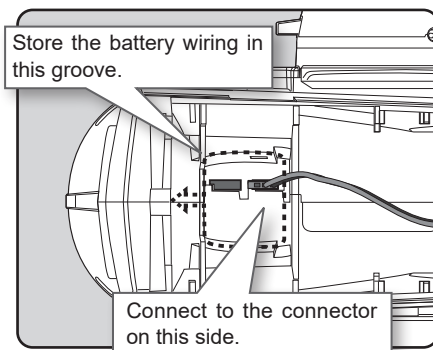
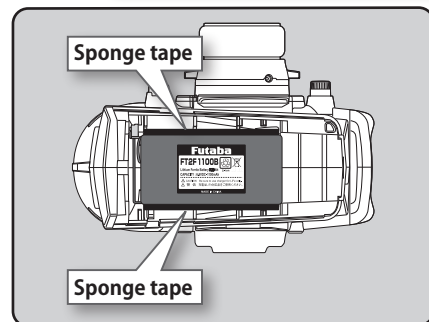

4 Finish by installing the battery cover.

⚠ Caution

❗ **When closing the battery cover, be careful that the battery cover does not pinch the battery lead wires.**

Shorting of the battery lead wires may lead to fire and abnormal heating and cause burns or fire disaster.

LiPo Battery LT2F2000B Replacement Method

When using an optional LiPo battery, replace the battery as described below.

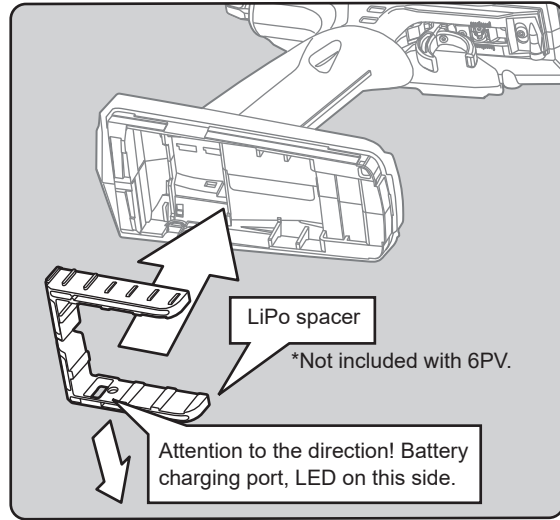
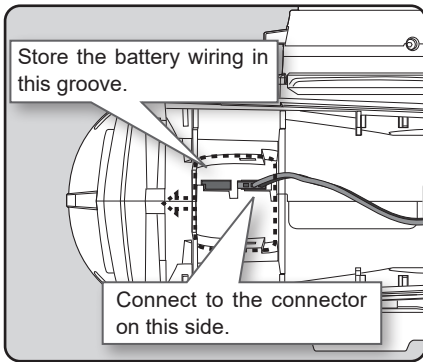
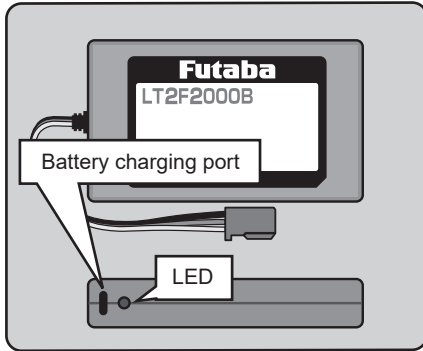

•LiPo battery installation

Install the LiPo spacer on the transmitter and then the LiPo battery.



Change the battery type, be sure to change the [Battery type] setting.

Change to a LiPo battery, go to [System menu] → [Battery] and change it to [Battery type] → **LiPo 2 cells**.

When Charging For The Optional LiPo Battery

To charge the battery, connect a type C USB cable to the Futaba optional USB AC adapter or a commercially available USB AC adapter (USB-A type 5 V-2 A) from the LiPo dedicated charging port.

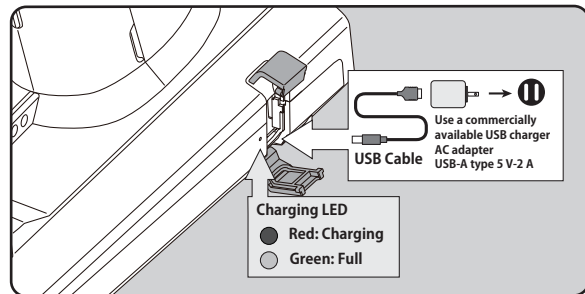
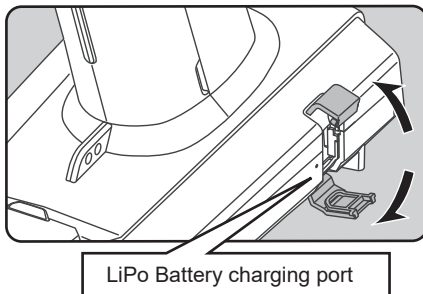

•Charging LED

Lights red while charging. When charging is complete, it lights up in green.



Warning

⊘ Do not charge the LiPo battery with ICS LF-01.

There is a risk of explosion or fire, which is very dangerous.

⚠ Always charge LiPo batteries with a LiPo battery charger.

Using a different charger, there is a risk of explosion or fire, which is very dangerous.

Steering Wheel Arrangement

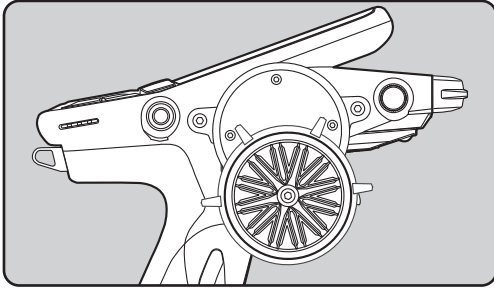

•Changing the wheel position

The wheel position can be offset by using the accessory APA(Adjustable Positioning Adaptor) wheel position offset adapter.

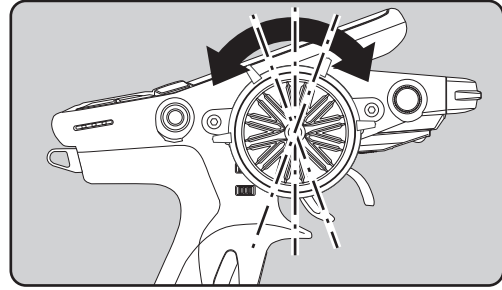

•Angle can be adjusted

The angle can be finely adjusted by adjusting the steering wheel unit installation.

[7.5 ° 48 steps]

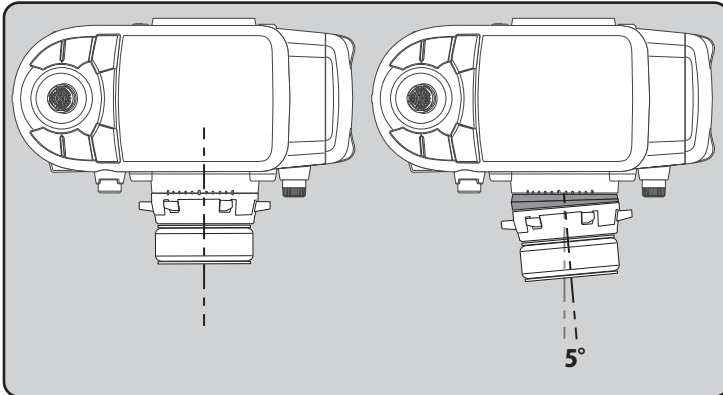

•Angle spacer

The wheel mounting angle can be changed by using the optional angle spacer 5°.

Exchange procedure to wheel adaptor 32 deg and large diameter wheel

The operating angle of the wheel can be adjusted

The operating angle of the wheel can be changed from 34 deg to 32 deg by installing the 32 deg wheel adjuster.

If you install the 32 deg wheel adapter, be sure to adjust the scale of the steering channel accordingly by using the "Calibration Function (System menu)".

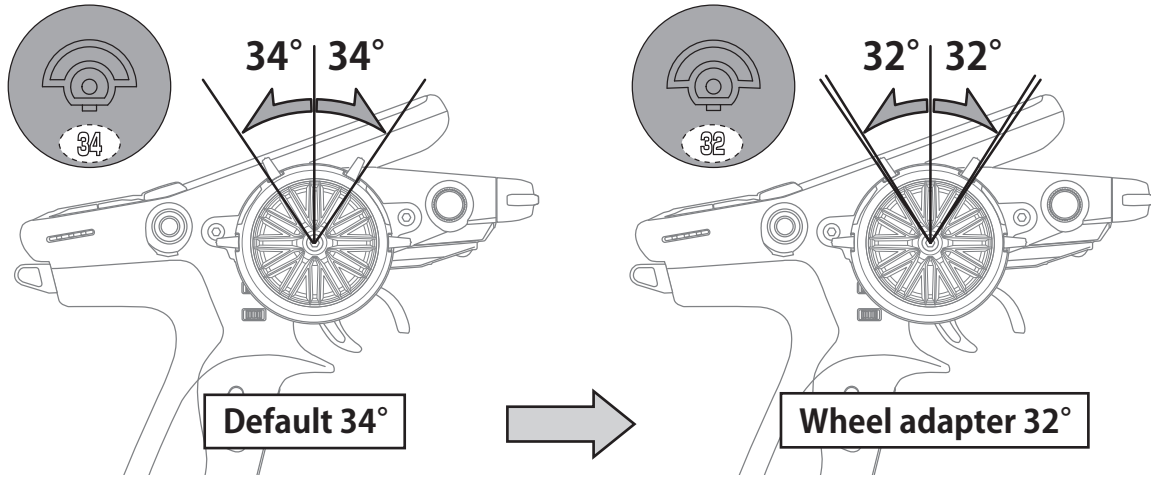

1 Hold the wheel and remove the screw.
(Using a hex wrench.)

2 Pull off the wheel and wheel adapter.

3 Install the standard or large diameter steering wheel and the 32 degree wheel adapter using the screw.
(Using a hex wrench.)

- Adjust the scale of the steering channel accordingly by using the "Calibration Function (System menu)".

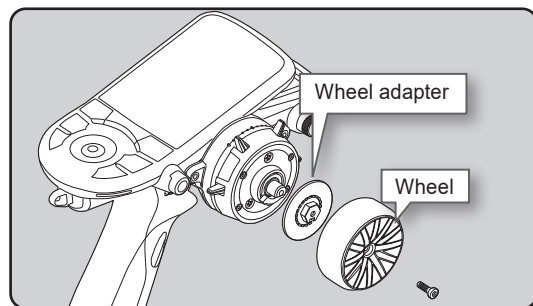
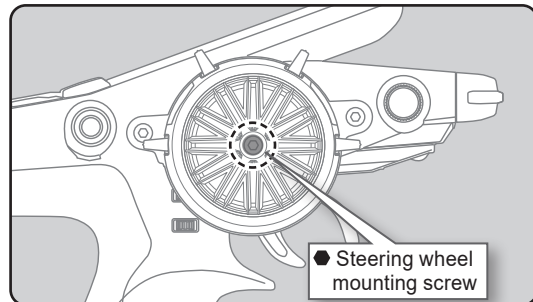

Installing the accessory APA steering wheel offset adapter

- Obtain hex wrench./ Remove the battery.

- 1** Remove the 2 steering unit mounting screws (M3x12 screw).
(Using a hex wrench.)

Remove the 2 mounting screws completely from the transmitter body.

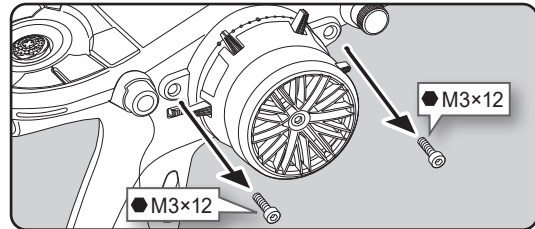

- 2** Gently remove the steering unit, without pulling excessively on the wiring.

- Remove the steering unit slowly so that the internal wiring is not pulled unreasonably.

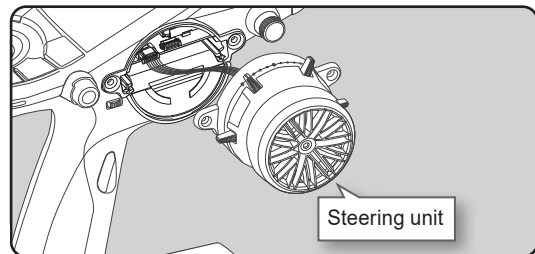

- 3** Remove a connector from the PC board.

Press the upper side of the connector to release the lock and remove it from the PC board.

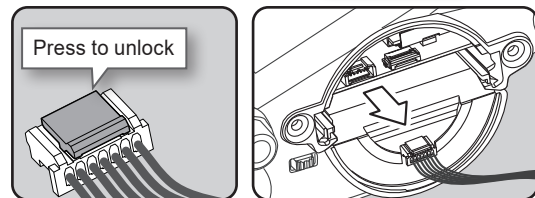

- 4** Hold the wheel and remove the screw.
(Using a hex wrench.)

- 5** Pull off the wheel and wheel adapter.

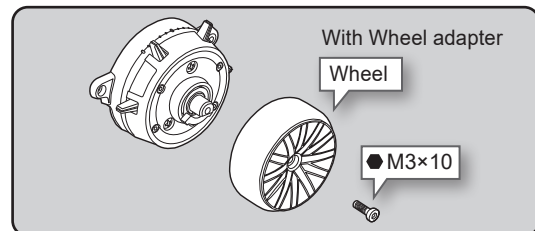

- 6** Using a hex wrench, remove the 4 screws (M2x19) mounting the wheel unit. Remove the wheel unit from the steering housing.

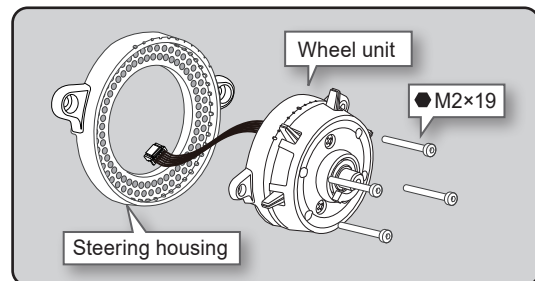

- 7** Pass the wiring from the wheel unit through the hole in the APA parts and steering housing as shown in the figure.

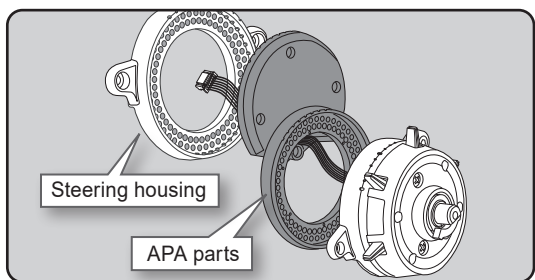
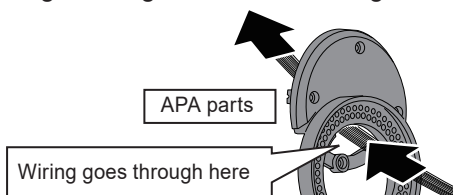

8 Pass the wiring from the wheel unit through the hole in the APA parts and steering housing as shown in the figure.

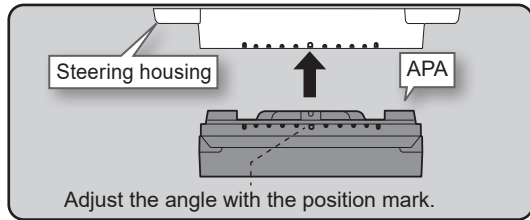
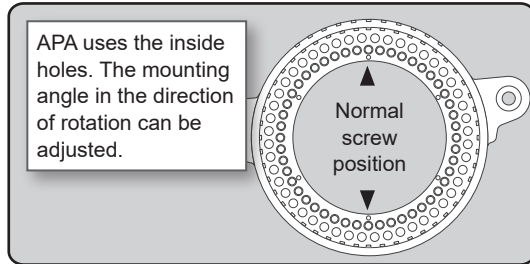

9 Attach the wheel unit to the APA with four M2×19 screws.

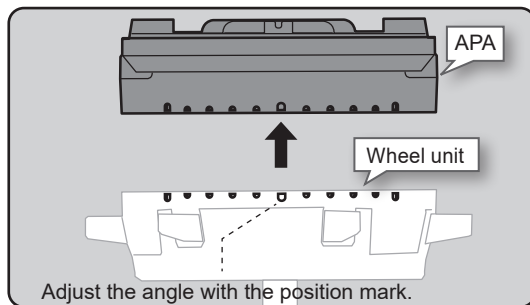

- The angle of the wheel rotation direction can be adjusted.

10 Connect the steering wiring to the transmitter.

- Attention to the connector direction

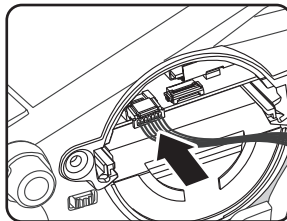

11 Attach the assembled steering unit to the body with two M3×12 screws.
(Using a hex wrench.)

12 Insert the wheel and hold the wheel and attach the screw.
(Using a hex wrench.)

- Install slowly so that the wiring is not pinched.

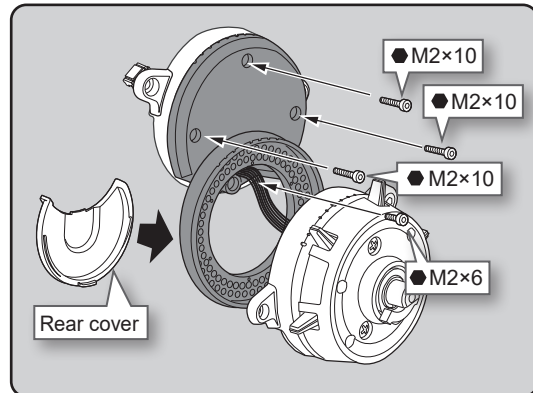

- Use the accessory screws and the transmitter screws.
- There are extra screws in the accessories.

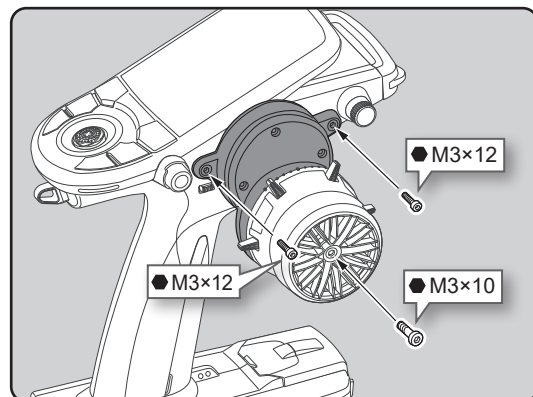
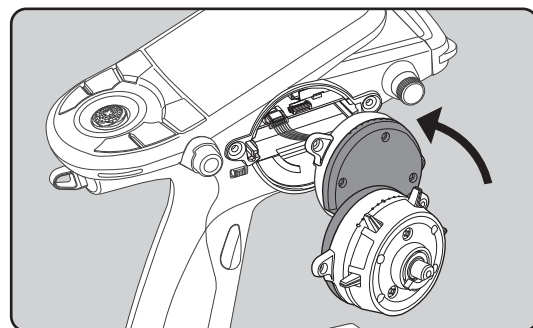
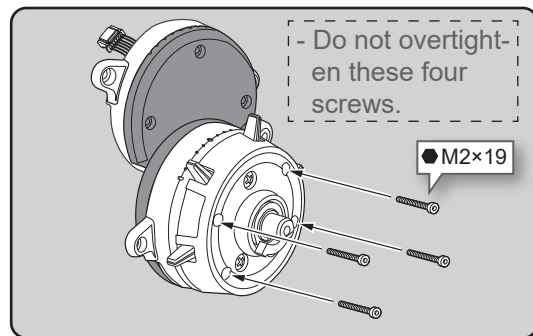

Angle Spacer

The wheel mounting angle can be changed by using the optional angle spacer 5°.

- The angle spacer use the included four M2x5 mm hex screws.
- Obtain hex wrench./ Remove the battery.
- The length of the screws used at each part differs. When reassembling the steering wheel unit, always use the specified screws.

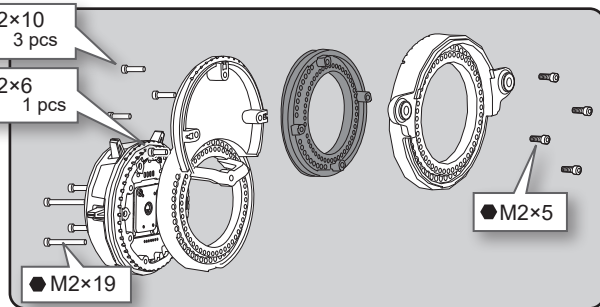
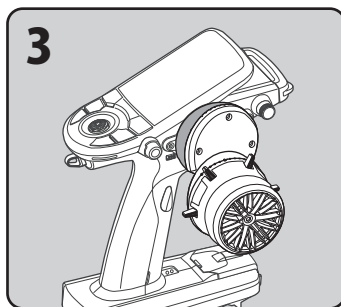
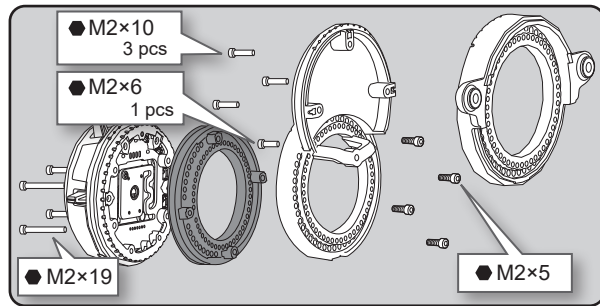
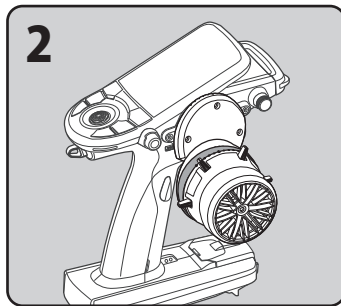
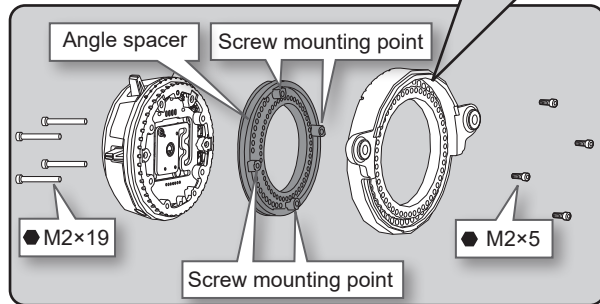
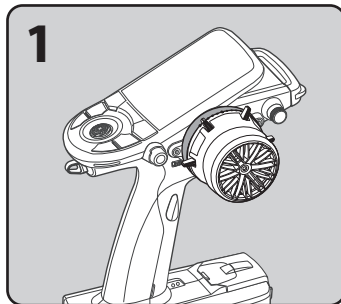
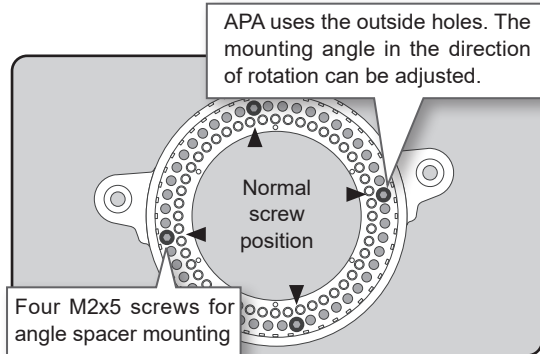
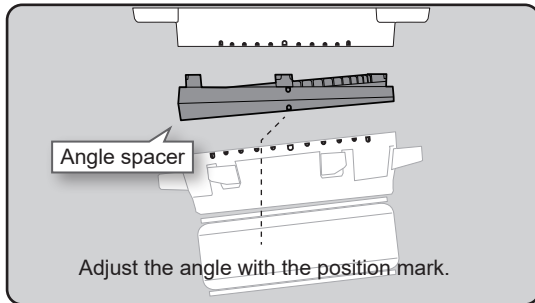

- Use the accessory screws and the transmitter screws.
- There are extra screws in the accessories.
- M2 x 5 screws are special size so be careful not to lose them.
- Do not overtighten M2x19 four screws.

Trigger Brake Lever Replacement

The trigger brake lever can be replaced with the optional trigger brake lever for T10PX / T7PXR / T7PX.

*When the brake lever is changed, perform throttle side correction by adjuster function.

Brake lever replacement

- 1 Hold the trigger, remove the brake lever mounting screw using the hex wrench, and remove the brake lever.
- 2 Using the hex wrench install the brake lever with the brake lever mounting screw.

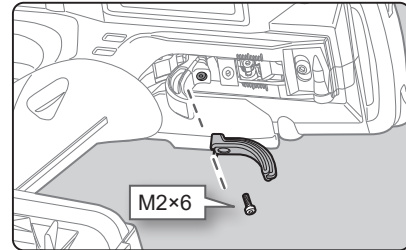

Handling The Antenna

About The Transmitter Antenna

Cannot rotate more than 90°. If rotated forcibly, the antenna will be damaged.

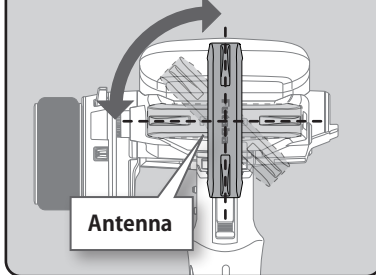

Antenna Moving Range

If the antenna is set to the 45° and 90° vertical position, the range of the radio waves may be greater than in the horizontal position. (Different depending on the conditions)

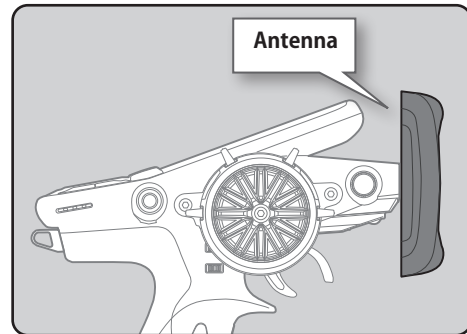

⚠ Caution

- ⊘ Do not grasp the transmitter's antenna while driving.
Doing so may degrade the quality of the RF transmission to the model.
- ⊘ The antenna position can be changed in the direction as shown in figure. However, please do not apply unnecessary force or shock.
The internal cable may be damaged; thus transmitting distance decreases and it may cause malfunction.

There might be a small glitch when the antenna of the transmitter is brought close to servos, ESCs or other peripheral devices.

This is not an issue but please keep this symptom in mind, especially when setting-up.

microSD port

T6PV model data and telemetry log data can be saved by using a commercial microSD card. When T6PV software updates are released, the microSD card can also be used to make the update.

Communication port

Connect compatible devices such as S.BUS servos and perform setup.

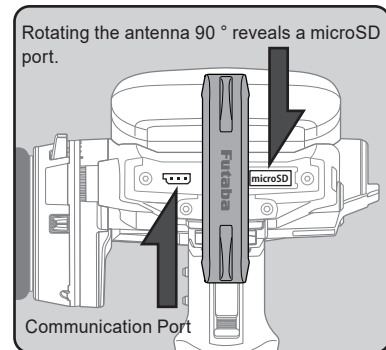

Receiver Terminology

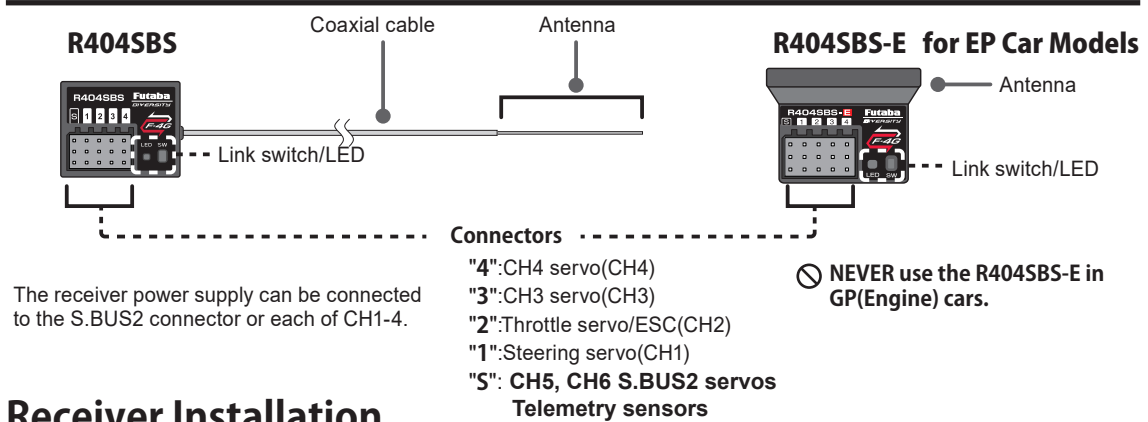

Receiver Installation

Install the receiver on the car as follows:

- NOTE:** The operating range may reduced, depending on where the receiver and the antenna are mounted.
- NOTE:** Put the antenna in the antenna tube to protect it. Do not let the tip go outside. (R404SBS)
- NOTE:** It is a receiver of diversity type with both external and internal antennas. Do not place wiring or other objects on the plate. The receiving range may be affected.



⊘ Do not install the receiver as shown on the left.

⊘ Do not put decals or double-sided tape on the antenna.

Antenna Antenna

R404SBS-E

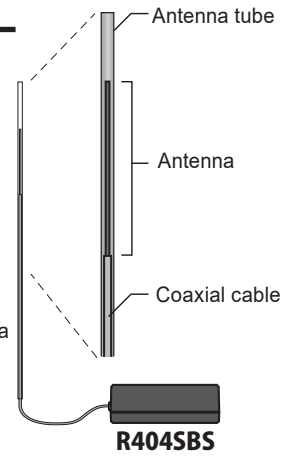

⚠ Warning

- ❶ Install the antenna in the higher place as shown in the figure.
- ⊘ Do not cut or bundle the receiver antenna wire. (R404SBS)
- ⊘ Do not bend the coaxial cable. It causes damage. (R404SBS)
- ⊘ Do not pull the receiver antenna or coaxial cable by force. (R404SBS)
- ❶ Keep the antenna as far away from the motor, ESC and other noise sources as you possibly can.
- ❶ Wrap the receiver with something soft, such as foam rubber, to avoid vibration. If there is a chance of getting wet, put the receiver in a waterproof bag or balloon.

⚠ Caution

❶ Always use R404SBS (-E) under the following conditions:

- Battery :Power requirement Rated voltage 3.7 to 7.4 V (dry cell battery cannot be used)
Matched to the ratings of the receiver and connected servo.
- Transmitter's receiver system > F-4G
- Use the servo that matches the servo type of each receiver response.

Under other conditions, the set will not operate, or the specified performance will not be displayed even if it operates. In addition, it may cause trouble with servos and other equipment. Futaba will not be responsible for damage, etc. caused by combination with the products of other companies.

Receiver And Servo Connections

Connect the receiver and servos as shown below. Connect and install the receiver and servos in accordance with "Installation Safety Precautions" on the next page.

The figure shown below is an example. The method of connecting the electronic speed controller to the motor and battery depends on the motor controller used. Purchase the electronic speed controller and servos separately. The receiver also depends on the set.

Installation when an electronic speed controller is used

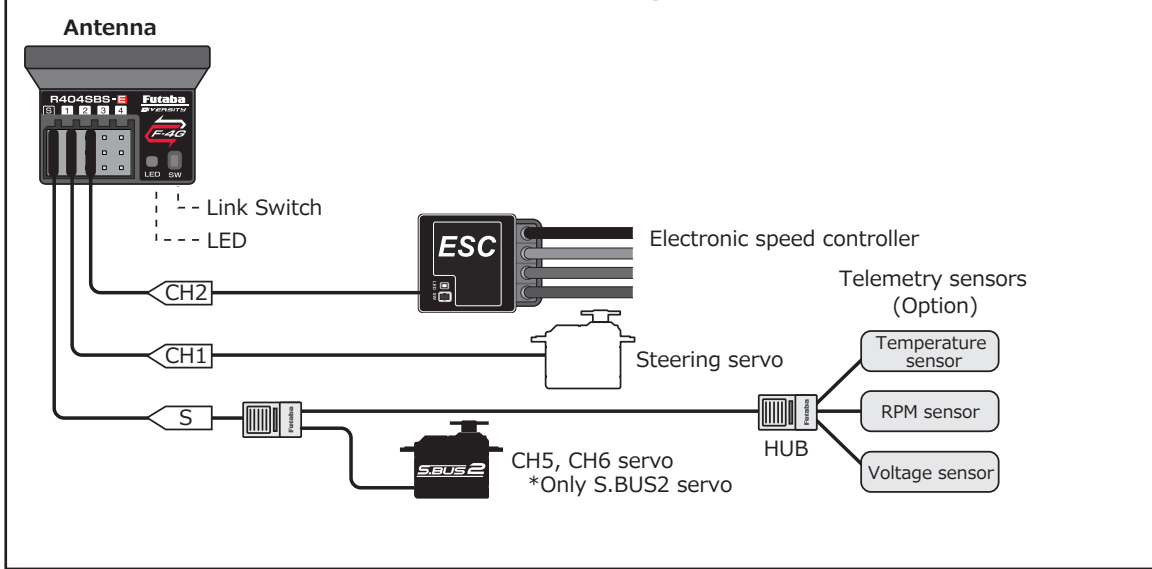

Installation For Gas Powered Models

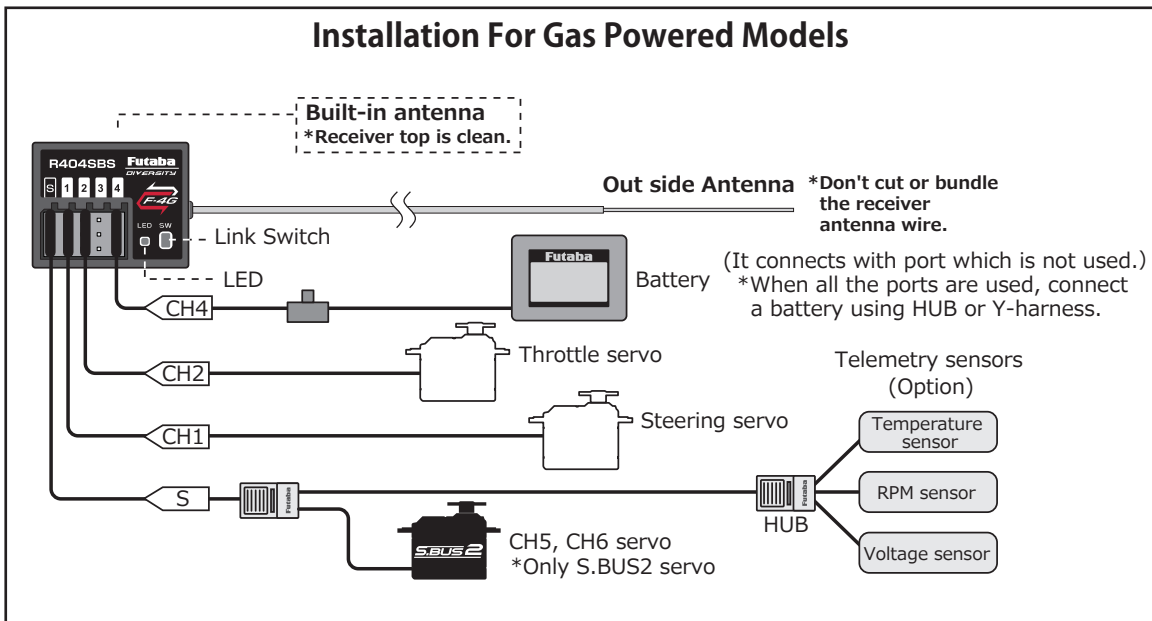

Installation Safety Precautions

⚠ Warning

Receiver (receiver antenna)

- ⊘ Do not cut or bundle the receiver antenna wire. (R404SBS)
- ⊘ Do not bundle the receiver antenna wire together with the ESC lead wire. (R404SBS)
- ⊘ Keep the receiver antenna at least 1 cm away from motor, battery, and other wiring carrying heavy current.
- ⊘ Do not use a metal receiver antenna holder on a plate made of metal, carbon, or other conductive material.
- ⊘ Since the antenna of built-in antenna receivers is installed under this, do not place wiring or other objects on it.

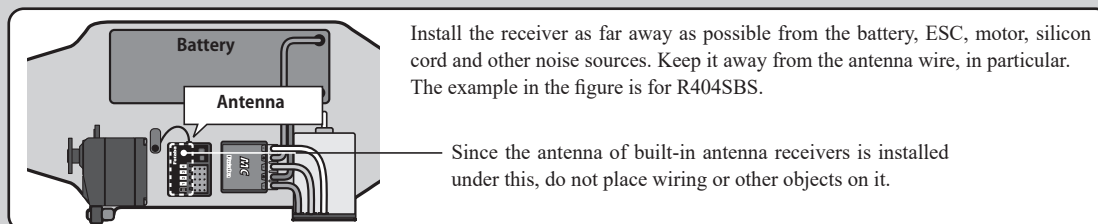

⚠ Warning

Receiver Vibration-proofing / Waterproofing

(Car)

- ❗ Vibration-proof the receiver by wrapping it in foam rubber or other vibration-absorbing material and mount it with thick double-sided tape.
- ❗ When using the receiver holder supplied with the model kit, mount the holder to the chassis through a rubber grommet.

(Boat)

- ❗ Vibration-proof the receiver by wrapping it in foam rubber or other vibration-absorbing material. Also waterproof the receiver by crusing it in a plastic bag.

If the receiver is exposed to strong vibration and shock, or the ingress of water, it may not operate correctly and you may lose control of the model.

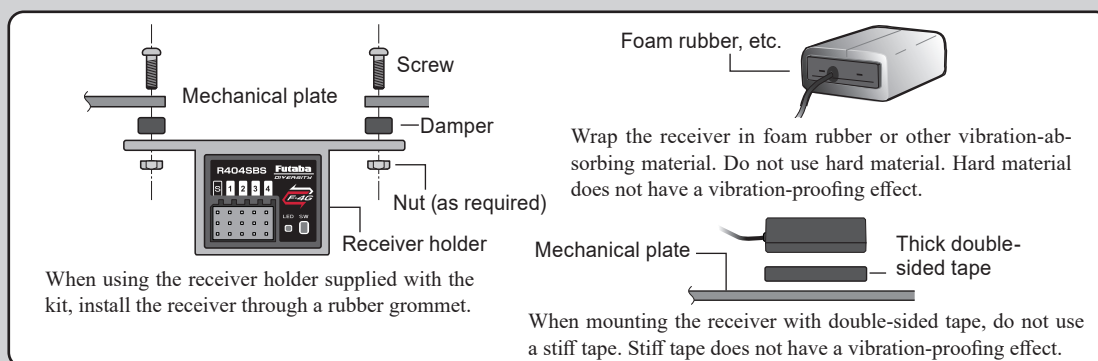

Connector Connections

- ❗ Be sure the receiver, servo, battery and connectors are fully and firmly connected.

If vibration from the model causes a connector to work loose while the model is in operation, you may lose control.

Servo Installation

- ❗ When you install the servos, always use the rubber grommets provided in servo hardware bags. Mount the servos so they do not directly come in contact with the mount.

If the servo case comes in direct contact with the mount, vibration will be directly transmitted to the servo.
If this condition continues for a long time, the servo may be damaged and control will be lost.

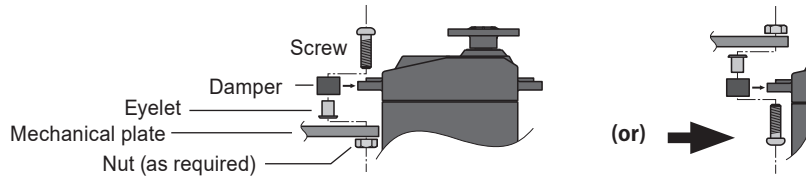

When installing the servo, always install the accessory rubber grommet and grommet flush against the servo.

A vibration-damping effect is not obtained if the rubber grommet and grommet are not installed correctly.

⚠ Warning Servo Throw

❗ Operate each servo over its full stroke and be sure the linkage does not bind or come loose.

The continuous application of unreasonable force to a servo may cause damage and excessive battery drain.

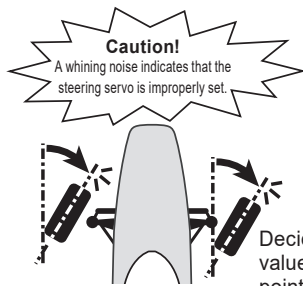

Adjust the steering servo so that unreasonable force is not applied to the servo by the chassis at maximum servo travel.

Decide the End point value at the contact point.

Adjust the throttle servo so that unreasonable force is not applied when the engine carburetor is fully open, fully closed, and the brakes are applied fully.

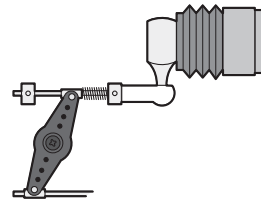

If the brakes overheat while running, their ability to function properly decreases. Before running, adjust the suitable maximum servo travel so that unreasonable force is not applied even when the servo travel is increased while running.

⚠ Warning Electronic Speed Controller

❗ Install the heat sinks where they will not come in contact with aluminum, carbon fiber or other parts that conduct electricity.

If the ESC (Electronic speed controller) heat sinks touch other materials that conduct electricity a short circuit could occur. This could result in loss of control and damage to the system.

Motor Noise Suppression

❗ Always install capacitors to suppress noise when electric motors are used.

If capacitors are not properly installed you could experience erratic operation and reduced range as well as loss of control.

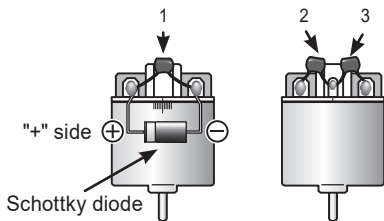

Motors with no suppressor capacitors, or inadequate suppression, may cause the receiver to malfunction. Always solder the capacitors supplied to your motor.

The Schottky diode improves the efficiency of the speed control / motor combination and provides extra protection to the brake FETs. The white ring must always face the positive side.

Other Noise Suppression Methods

❗ Be sure there are no metal parts in your model which under vibration can come in contact with other metal parts.

Metal to metal contacts under vibration will emit a high frequency noise that will affect the receiver's performance. You could experience erratic operation and reduced range as well as loss of control.

Menu Selection

This section explains how to operate the basic screens. The jog keys and DIR/END buttons are used to operate the screens.

*You can return to the home screen from each screen by pressing and holding the END button.

Display Menu Screen

Press Press and hold

Press [DIR] on the home screen to display the "User menu" screen.

Operate the jog key in either direction on the home screen to display the "Menu" screen.

(User menu screen)







(Menu screen)

Calling the endpoint screen /Returning from the endpoint screen to the home screen

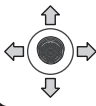
(Home screen) (Menu screen) (Linkage menu) (End point) (Menu screen)

Jog Key END button Press and hold

Jog key/DIR/END Button

- 
 - Move the jog key up, down, left and right to move the cursor. Press the jog key to set the data at the cursor position.
- 
 - If the screen has several pages, move the jog key left or right to move between the pages of the screen.
- 
 - Pressing the END button on the menu screen or any setting screen will return to the previous screen.
- 
 - Press and hold the END button on the menu screen or any setting screen to return to the home screen.
- 
 - Use the ± button to change the value/setting. Pressing the ± buttons simultaneously will reset the value to the initial value.
- 
 - Press and hold the END button on the home screen to activate the trim lock, disabling operation of the T6PV's main unit's digital trims DT1 to DT6 and dial DL1.
- 
 - Assign your preferred function screen to the DIR/END button and move to it with one touch.

How to assign your desired function screen to DIR/END button.

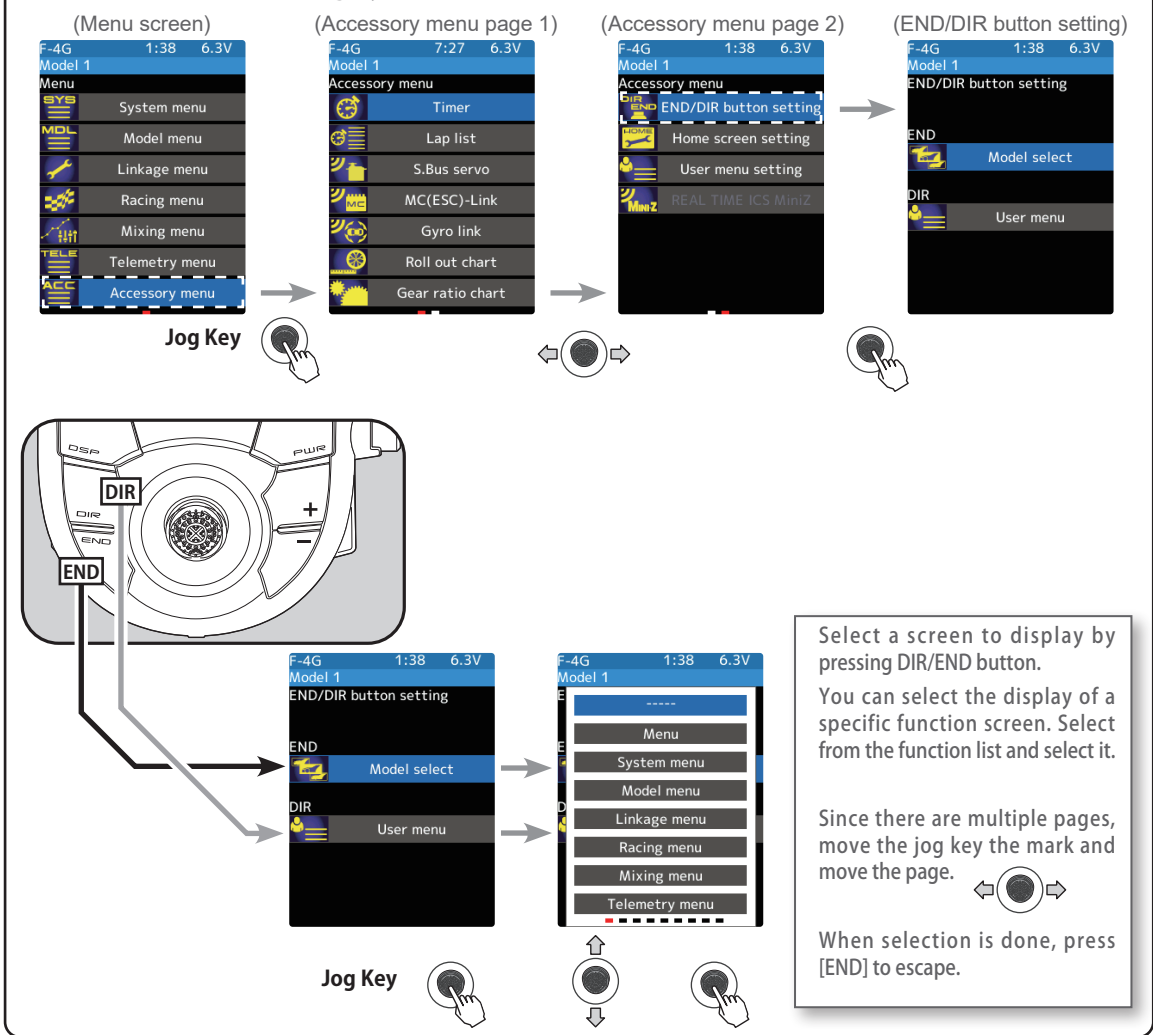

Value Of Each Function And Changing The Set Value

On the setting screen for each function, to increase or decrease the data value, select the item with the jog key and press the [+] or [-] button to set. Pressing the [+] and [-] buttons simultaneously will return to the initial value.

*The example below shows the endpoint screen.

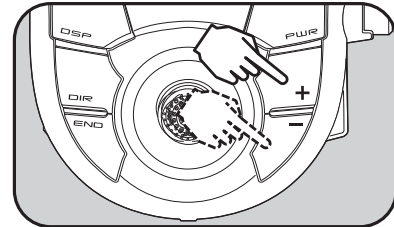
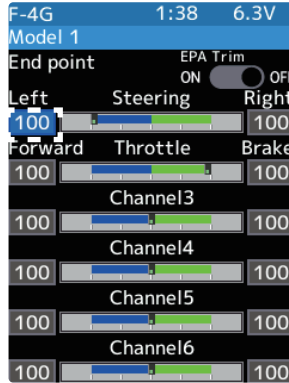
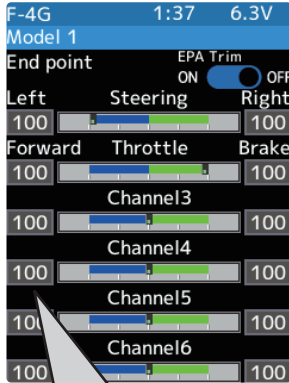

Use +/- buttons to set the value

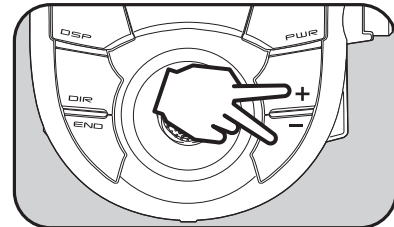

Press +/- buttons simultaneously to return to default value

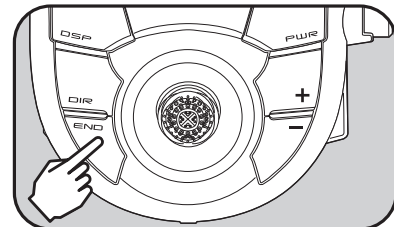

Press END to complete the setting

For items surrounded by a frame like this, you can change the settings using the +/- buttons.

± Button



Use the jog keys to select the value want to set.

To switch between ON and OFF, select (ON●) or (●OFF) with the jog key and press it to ± button from ON to OFF or from OFF to ON.

*The example below shows the Battery screen.

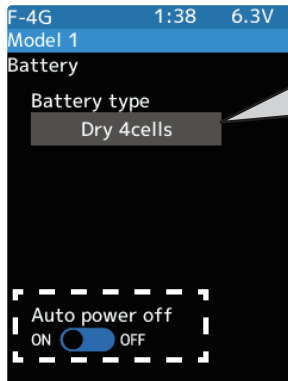

Items that are not enclosed in a frame like this can be operated with pressing the jog key (link operation, opening a selection screen, etc.).



Select with Jog key

± Button

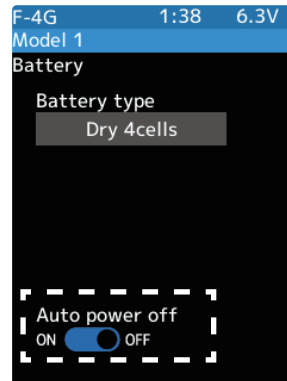

Linking Method For F-4G System

(Display when power switch turned on)

When the power switch is turned on, the currently selected model number is displayed. Check if this number is the model number you want to set-up. To change the model number, use the Model Select function.

Turn on the transmitter power.

Receiver system check

Voltage check

(HOME screen)

The model number is displayed.

Before setting up each function of the transmitter, check and set the following items.

RF Output & Rx Type Check

Check if the receiver system is set to the type of receiver used.

*When the "PWR" side power switch is set to ON and radio waves are output normally, F-4G/T-FHSS/S-FHSS/MINI-Z EVO/MINI-Z EVO2/MINI-Z FHSS is displayed. If not displayed, there is probably an abnormality or trouble so contact a Futaba Service Center. When a screen is displayed at the "DSP" side, "Display" is displayed.

*Since the R404SBS(E) receiver supplied with the T6PV set uses the F-4G system, T6PV receiver setup must be set to F-4G.

Receiver system Change & How To Link

First set up the receiver. Setting changes are immediately reflected. Next, the transmitter and receiver are linked and the receiver memorizes the transmitter ID number so that signals from other transmitters will not be received. In addition, with the Telemetry system, the transmitter simultaneously memorizes the receiver ID numbers so that data from other receivers will not be received.

The method of setting up the receiver system and the method of linking the transmitter and receiver are described.

- 1** Set the transmitter "PWR" side power switch to ON. From the Home screen, Operate the jog key in either direction. Next, select [Receiver] at the Linkage menu and access the setup screen shown below by press the jog key.



2 In "Receiver", select and press the jog key the system to be set from the systems. If you change the system, be sure to link it with the receiver and turn the power on again.

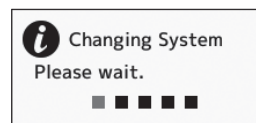
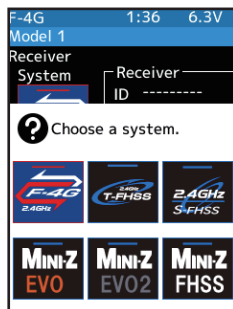

Select the system to be set from F-4G/T-FHSS/S-FHSS/MINI-Z EVO/ MINI-Z EVO2/MINI-Z FHSS.

* Even with the same receiver, if you change the system, be sure to link with the receiver and power cycle the receiver.

3 For the F-4G system, select [Analog Servo] [Digital Servo] [SR mode] [UR mode] in the receiver setting "Response" and make changes. UR/SR mode require their own dedicated servos. The display changes when the mode is changed. When using normal servo or ESC, set the Digital servo or Analog servo.

- UR mode: UR servo (Set to UR mode)
- Digital servo

- SR mode: SR servo (Set to SR mode)
- Analog servo

Note: In UR/SR mode ON, normal servo, ESC, and standard gyro will not operate.

4 When using battery fail-safe, set the Battery Fail-safe Voltage in the "Fail-safe" in the "Linkage menu".

*In the F-4G system, the Battery Fail-safe voltage is set at the time of linking. Relink when changing Battery Fail-safe voltage.

5 Bring the transmitter and receiver within 50 cm of each other (antennas do not touch) and turn on the receiver power.

6 Select [Link] on the transmitter T6PV screen, you will hear a chime sound and T6PV will enter the link mode for 20 seconds.

7 During the 20 seconds link mode, press the receiver push switch for at least 2 seconds. The LED blinks red and then changes to a greenish red → green steady light. When the T6PV makes a beeping sound and the message "Link with receiver" appears on the screen, release the receiver push switch. This ends reading of mutual ID and displays the memorized receiver ID number on the T6PV screen. Power cycle the receiver. If the "Receiver not found" error screen is displayed, linking failed. Check the set contents and repeat the linking operation.

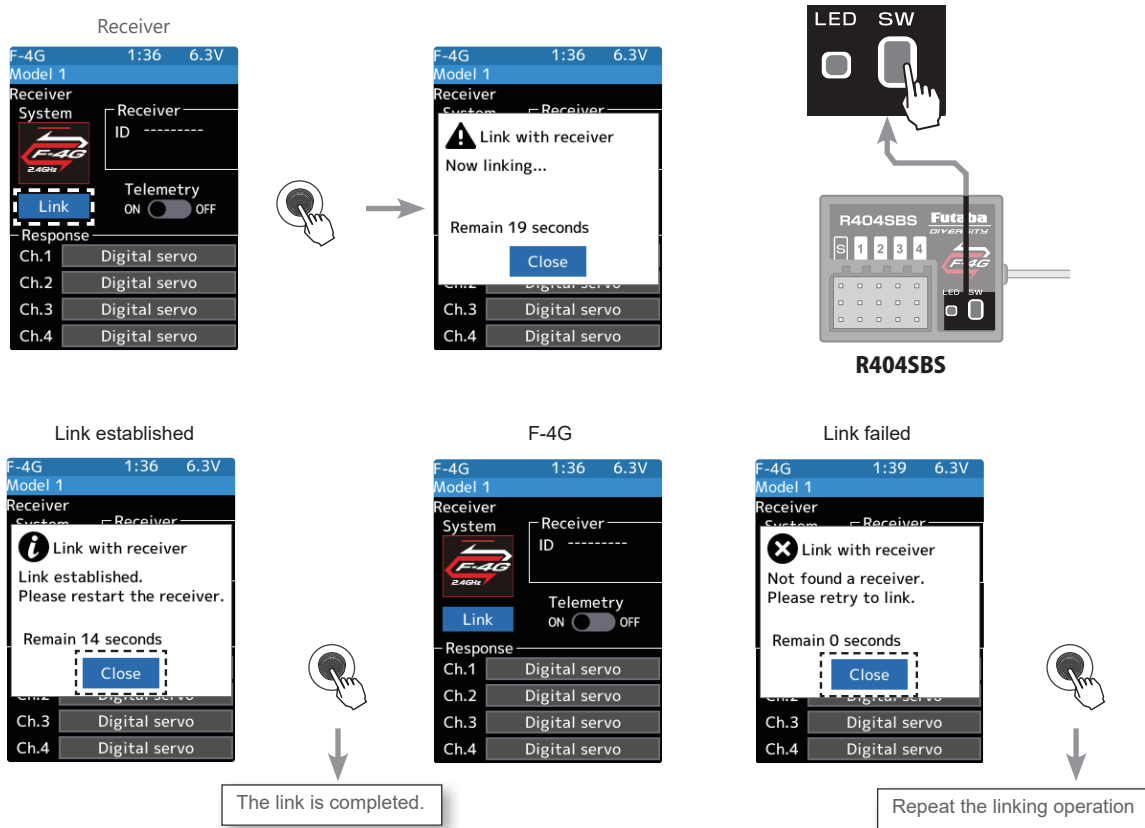

8 Once the settings are complete, turn the receiver off and then on again. The response and battery fail-safe voltage settings will take effect after the receiver is restarted.

*The T6PV and F-4G receiver (R404SBS/R404SBS-E)/T-FHSS receiver memorize the IDs linked last at each model memory. Since only one receiver ID is memorized at each model memory, multiple F-4G/T-FHSS receivers cannot be used with the same model memory. When a receiver at the same model memory is changed, re-linking is necessary even if the receiver is already linked with the transmitter.

*When using multiple F-4G/T-FHSS receivers, link each receiver with each T6PV model memory. However, one receiver can be linked with multiple model memories.

*The telemetry function communication status can be checked at the T6PV home screen.

*For other than F-4G system, the link procedure is different.

Link notice

⚠ WARNING

⚠ Do not perform the linking procedure with motor's main wire connected as it may result in serious injury.

⚠ After the linking is done, please cycle receiver power and check if the receiver to be linked is really under the control of the transmitter to be linked.

■ The settings will not be reflected unless restart.

This manual is a simplified version. Detailed of each function are not described. Refer to your countries distributor website for the full manual and update contents download.

<https://futabausa.com> (<https://www.rc.futaba.co.jp>)

FUTABA CORPORATION

1080 Yabutsuka, Chosei-mura, Chosei-gun, Chiba-ken, 299-4395, Japan
TEL: +81-475-32-6051, FAX: +81-475-32-2915

©FUTABA CORPORATION 2024, 11 (1)



DIGITAL PROPORTIONAL R/C SYSTEM

T6PV

<https://futabausa.com>

<https://www.rc.futaba.co.jp>

Futaba®