

01 Disclaimer

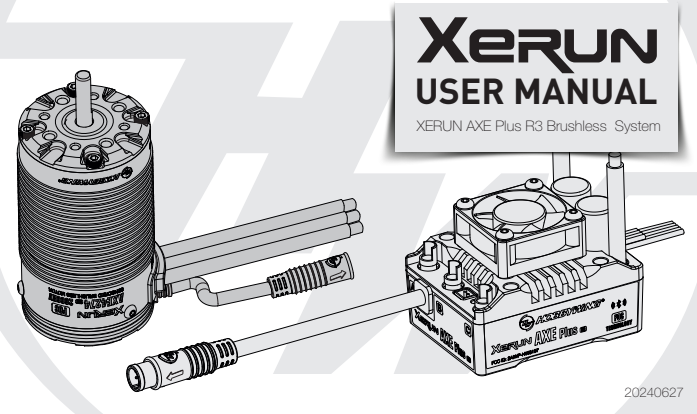

Thank you for purchasing this HOBBYWING product! Any improper use may cause personal injury and damage to the product and related devices. We strongly recommend reading through this user manual before use. Since we have no control over the use, installation, or maintenance of this product, no liability may be assumed for any damage or losses resulting from the use of the product. We do not assume responsibility for any losses caused by unauthorized modifications to our product. We, HOBBYWING, are only responsible for our product cost and nothing else as result of using our product.

02 Warnings

- Ensure all wires and connections are well insulated before connecting the ESC to related devices, as short circuit will damage your ESC.
- Ensure all devices in the system are connected correctly to prevent any damage to the system.
- Read through the manuals of all power devices and chassis and ensure the power configuration is correct before using this unit.
- Please use a soldering iron with the power of at least 60W to solder all input/output wires and connectors.
- Do not allow the ESC & motor temperatures (external temp.) go above 90°C/194°F, as high temperature may cause damage to both the ESC and motor.
- The battery must be disconnected after use. There is a small draw even when the system is off, and will eventually fully drain the battery. This may cause damage to the ESC, and will NOT BE COVERED UNDER WARRANTY.

03 Features

- FOC(Field Oriented Control) driving mode to the power system of rock crawler. The low speed torque is very strong. This improves over standard brushless setups and is even preferred over the brushed setups for overall feel.
- The chip-type magnetic encoder inside the motor guarantees consistency between three phases' signals and always outputs the pure and precise signals indicating the rotor position.
- The waterproof and dust-proof design (IP67 standards) allows the AXE brushless power system to be used in all weather & track conditions without any issue of damage caused to the system from water or dust. Damage to the vehicle caused by water, mud, or conditions should be monitored closely when running in muddy, wet, or adverse conditions.
- Intelligent torque output & speed closed-loop control for easy control, and consistent motor RPM under all loads.
- The adjustable drag brake & drag rate control with the maximum drag brake of up to 200% (that's nearly twice the drag brake of standard brushless power systems) can provide unprecedented Holding Power on slopes.
- The innovative built-in Bluetooth connectivity allows users to set ESC or read ESC data or update ESC firmware via a smart phone (installed with the HW LINK app).
- Multiple protections: low-voltage cutoff, thermal, fail safe (throttle signal loss), motor lock-up, and battery reversal.

04 Specifications

Model	XERUN AXE Plus R3							
Cont/Peak Current	135A/600A							
Motor Type	Only the XERUN AXE R3/R2 Series							
Applications	1/10&1/8&1/6 Rock Crawler							
LiPo Cells	2-6S Lipo							
BEC Output	6V/7.4V/8.4V adjustable, Continuous Current of 6A							
Size	49.5(L)x37.9(W)x32.8(H)mm(w/Fan)							
Weight	126.5g(Included input wires&connector)							
ESC Programming	iOS or Android smart phone (installed with the HW LINK app)							

Motor Model	KV (No-load)	Recommended Lipos	No-load Current	Motor Diameter Length	Shaft Diameter Length	Poles	Weight	Applications
XERUN AXE50 R2-2300KV	2300KV	2-3S	2.5A	36.0/49.8 mm 1.42/1.96 in			185g	
XERUN AXE540L R2-1400KV	1400KV	2-4S	1.7A		3.175/16.0 mm 0.125/0.63 in		232g	1/10 Crawler
XERUN AXE540L R2-2100KV	2100KV	2-4S	2.7A	36.0/57.8 mm 1.42/2.28 in		4	233g	
XERUN AXE540L R2-2800KV	2800KV	2-4S	3.6A				234g	
XERUN AXE550 R2-3300KV	3300KV	2-3S*	4.7A	36.0/63.8 mm 1.42/2.51 in	5/16.0 mm 0.197/0.63 in		268g	1/10&1/8 Crawler
XERUN AXE4274 R3-1700KV	1700KV	3-6S	4A	42.7/74 mm 1.65/2.91 in	5/20.5 mm 0.197/0.73 in		405g	1/8&1/6 Crawler
XERUN AXE4274 R3-2000KV	2000KV	3-6S	4.5A				415g	

*Note: The AXE550 R2-3300KV motor can also use the 4S Lipo, but the esc limits the throttle output to a maximum of 85%.

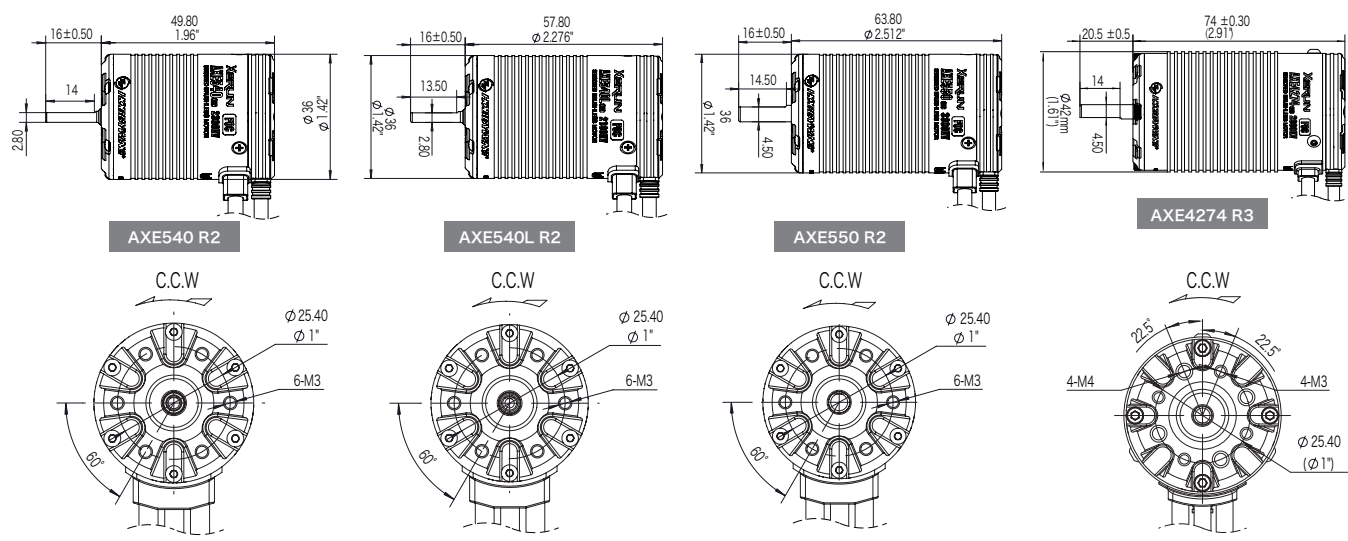

05 Connections

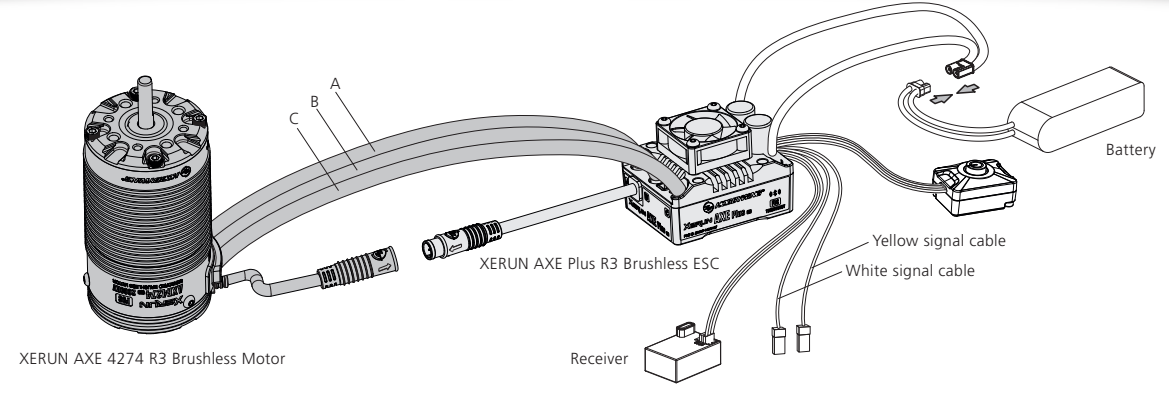

This is an extremely powerful brushless motor system. For your safety and the safety of those around you, we strongly recommend removing your pinion gear before performing calibration and programming functions with this system, and keeping wheels in the air when you turn on the ESC.

- Motor Connection**
There is strict wiring order from the ESC to the motor, the three A/B/C ESC wires must connect to the three A/B/C motor wires correspondingly. Next, connect the sensor cable of the esc and motor according to the arrow mark on the sensor connector.
Note: AXE Plus R3 esc only supports AXE R3/R2 series motors and does not support the use with other types of motors.
Please make sure that the sensor connector of esc and motor is connected according to the arrow direction and tightened. Improper use may damage the internal structure of the sensor connector or cause water ingress, which may lead to abnormal operation.
If the motor direction is reversed, change the parameter on item "Motor rotation" to achieve the correct setting.
- Receiver Connection**
Insert the throttle cable of the ESC into the throttle channel of receiver. Because the red wire of throttle cable output BEC voltage to receiver and steering servo, do not supply any other power source to the receiver, otherwise the ESC may be damaged. If an external power supply is needed, unpin the positive (Center wire) from the receiver plug, insulate and secure the plug pin out side of the receiver plug.
White signal cable: This cable is used to connect the AUX/Idle channel of the receiver and achieve the function of real-time setting of esc's parameter through the transmitter. The default parameter item is "Drag Brake Force" and other parameter items can also be specified through item 20 "AUX3 channel function".
Yellow signal cable: This cable is also used to connect the AUX/Idle channel of the receiver and achieve the function of real-time setting of esc's parameter through the transmitter. The default parameter item is "Drag Brake Rate" and other parameter items can also be specified through item 2 "AUX4 channel function".
- Battery Connection**
Proper polarity is essential. Please ensure positive (+) connects to positive (+), and negative (-) connects to negative (-) when plugging in the battery! When reverse polarity is applied to the ESC from the battery, it will not function.

06 ESC Setup

1 Set the Throttle Range - ESC Calibration Process
You must calibrate throttle range when you begin to use a new ESC, the transmitter has been replaced, or the Throttle TRIM have been adjusted, otherwise the ESC will not work correctly. We recommend activating the "Fail Safe" function of the radio system and set it (FS) to "Output OFF" or set its value to the "Neutral Position" to ensure the motor can be stopped when there is no signal received from the transmitter.
To calibrate your ESC to your radio's Neutral, Throttle, and Brake, or set the throttle range, please follow the steps here:

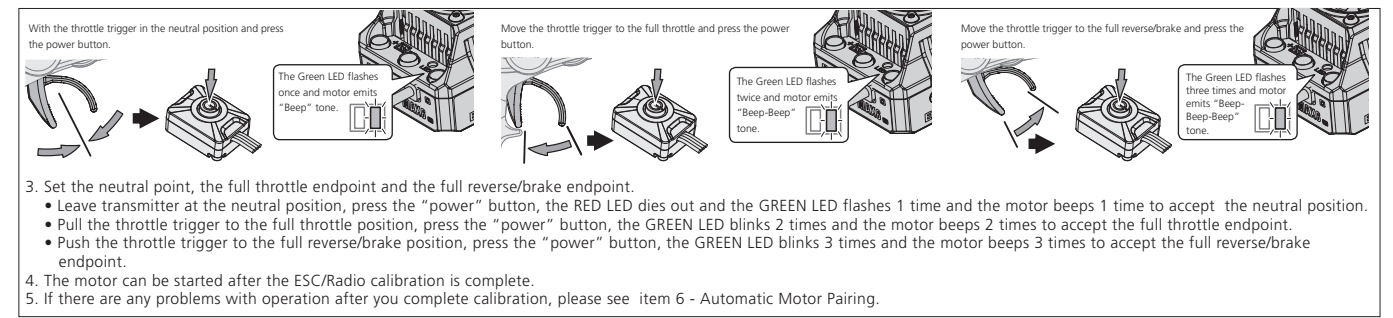
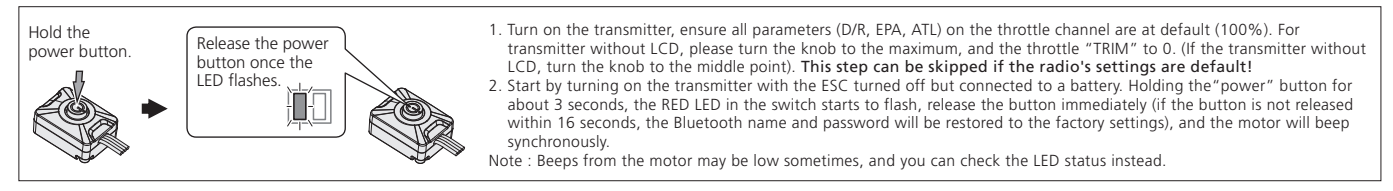

2 Power On/Off & Warning Tones

- Power ON/OFF:**
Short press the power button to turn on the ESC in the off state, and long press the power button to turn off the ESC.
- Warning Tones:**
Turn on the ESC, the motor will beep the number of LiPo cells you have plugged in. For example, 3 beeps indicate a 3S LiPo, 4 beeps indicate a 4S LiPo. The last long beep is a confirmation sound, indicating that the self-check is completed.

3 Programmable Items

Item #	Programmable Item	Option 1	Option 2	Option 3	Option 4	Option 5	Option 6	Option 7	Option 8	Option 9
1	Running Mode	Forward and Reverse	Forward/Reverse with Brake							
2	RPM/Throttle Matching	Disabled	Low	Intermediate	High					
3	LiPo Cells	Auto	2S	3S	4S	5S	6S			
4	Cutoff Voltage	Disabled	Low	Intermediate	High					
5	BEC Voltage	6.0V	7.4V	8.4V						
6	Smart Fan	Disabled	Enabled							
7	Motor Rotation	CCW	CW							
8	Max. Forward Force	25%	37.5%	50%	62.5%	75%	87.5%	100%		
9	Punch				1-15 (default: 8)					
10	Neutral Range				3%-15% (default: 8%)					
11	Initial Throttle Force				1%-15% (default: 1%)					
12	RPM Decrease Rate	Level 1	Level 2	Level 3	Level 4	Level 5	Level 6	Level 7	Level 8	Level 9
13	Max. Reverse Force	25%	37.5%	50%	62.5%	75%	87.5%	100%		
14	Max. Brake Force				10%-200% (default: 100%)					
15	Drag Brake Force				0%-200% (default: 80%)					
16	Smart Drag Brake Rate	Disabled	Enabled							
17	Drag Brake Rate				1-15 (default: 8)					
18	Turbo Timing				0-24° (default: 0°)					
19	Turbo Delay	Instant	0.05S	0.10S	0.15S	0.20S	0.3S	0.5S	0.7S	1.0S
20	AUX3 CH Function (White cable)	8	9	12	13	14	15	17	18	19
21	AUX4 CH Function (Yellow cable)	8	9	12	13	14	15	17	18	19

Note: those black-and-white options are default values.

- Running Mode**
Option 1: Forward and Reverse
This mode is often used by rock crawler. It adopts the "SINGLE-CLICK" method. The vehicle will reverse immediately when the throttle trigger is pushed to reverse position.
Option 2: Forward/Reverse with Brake
This mode provides normal/standard throttle operation for non rock crawling usage. The vehicle only brakes on the first time you push the throttle trigger to the reverse/brake position. If the motor stops when the throttle trigger return to the neutral position and then re-push the trigger to reverse position, the vehicle will reverse, if the motor does not completely stop, then your vehicle won't reverse but still brake, you need to return the throttle trigger to the neutral position and push it to reverse again. This method is for preventing vehicle from being accidentally reversed.
- RPM/Throttle Matching**
About this function, the ESC will automatically adjust the motor torque when the load of the vehicle changes. You can adjust the ability of the vehicle to maintain speed when encountering resistance through the options, the higher this value is set, the stronger the ability to maintain speed (the greater the torque increased), which means that the vehicle speed changes less with resistance. If this value is set to "Disabled", it is similar to normal brushed or brushless power system, the ESC will not automatically adjust the motor torque when the load of the vehicle changes.
- LiPo Cells**
Set the correct value according to the actual number of LiPo cells used. The default is automatically calculated. To prevent misjudgment (such as misjudging a uncharged 4S Lipo as a fully charged 3S Lipo), it is recommended that you manually set the correct number of LiPo cells.
- Cutoff Voltage**
Low Voltage Cutoff for LiPo Protection. This item is mainly for preventing the LiPo pack from over-discharge. If the low-voltage cutoff protection is enabled, the ESC will monitor the battery voltage all the time and gradually reduce the output to 50% (in 3 seconds) and cut it off about 40 seconds later when the voltage goes below the cutoff threshold. The Red LED will flash a single flash that repeats (→, →, →, →, →) when the ESC enters the low-voltage cutoff protection. The ESC will not cut off the power when the voltage is low if the low-voltage cutoff protection is disabled. We don't recommend setting the "Cutoff Voltage" to "Disabled" when using a LiPo pack, otherwise, the battery will be damaged due to over-discharge.
• For NiMH battery, we recommend setting this item to "Disabled".
• Voltage - The specific voltage values correspond to "Low/Intermediate/high" are 3.0V/3.2V/3.4V per cell. Please note, due to a number of variables you may not see exactly these same voltage values.
- BEC Voltage**
BEC voltage supports 6.0V/7.4V/8.4V adjustable, generally 6.0V is applicable to common steering servo, if high voltage steering servo is used, it can be set higher. Please refer to the steering servo voltage identification for specific setting voltage.
Note: 1. Do not set the BEC voltage above the maximum operating voltage of the servo, as this may damage the servo or even the ESC.
2. Due to the characteristics of the BEC circuit, there is a voltage difference between the BEC output voltage and the input voltage, when the BEC voltage is set to 7.4V/8.4V and 2S Lipo is used, the BEC cannot stably output 7.4V/8.4V (will decrease as the battery voltage decreases). Therefore, it is recommended to use 7.4V/8.4V BEC when matching with 3S Lipo and above.
- Smart Fan**
This esc has a fan control function. If this item is set to "Disabled", the fan will continue to run after the ESC is powered on; if this item is set to "Enabled", the fan will start running after the internal temperature of the esc exceeds 50°C/122°F.
- Motor Rotation**
This feature allows the changing of the motor's forward direction. To check, look at the motor with the shaft facing you. If the motor spins counter clockwise if this item is set to CCW, the motor spins clockwise if set to CW. The drive train of your chassis will determine what direction motor you should use. Some vehicles use normal or CCW rotation, other vehicles use CW or backwards rotation motors.
- Max. Forward Force**
It's the force when throttle trigger is at the full throttle position. You can lower down the value for better driving feel/control when you drive a crawler (simulation model) over difficult terrains (and don't have any requirement against the maximum speed).
- Punch**
Punch can be used to control overall motor response in relation to the throttle input. The higher the set value, the faster the acceleration. Lower punch settings are advised for softer starts, lower traction, or to help with motor hesitations or stuttering when throttle is applied rapidly.
- Neutral Range**
As not all transmitters have the same stability at "neutral position", please adjust this parameter as per your preference. You can adjust to a bigger value when this happens. The neutral range is the "dead zone" or "dead band" of the throttle/brakes. If you notice inconsistent drag brakes, you would increase your neutral range value.

- Initial Throttle Force**
It also called as minimum throttle force. Adjusting this setting to the available traction can help with acceleration. Set a lower value for low traction surfaces, and higher values for higher traction surfaces.
- RPM Decrease Rate**
This refers to the speed of rpm change when reducing the throttle (from high to low throttle), the higher the value, the faster the change. If you want to achieve the experience of natural sliding when reducing the throttle like normal brushless power, this value needs to be set to a low level.
- Max. Reverse Force**
The reverse force of the value will determine its speed. For the safety of your vehicle, we recommend using a low amount.
- Max. Brake Force**
This ESC provides proportional braking function, the braking effect is decided by the position of the throttle trigger. It sets the maximum brake force when the throttle trigger is at the full brake position. Large amount will shorten the braking time but it may damage your pinion and spur gear. Please set the appropriate value according to the vehicle's condition.
- Drag Brake Force**
It is the braking power produced when the throttle is at the neutral position. (Attention! Drag brake will consume more power and heat will be increased, apply it cautiously.) Higher drag brake means stronger hold or hill brakes.
- Smart Drag Brake Rate**
When this parameter is set to Enabled, the esc will detect the speed of the motor during running, if the speed is higher, the longer it takes to reach the set value of the drag brake rate (item 17), that is, the slower the drag brake is applied. This helps to prevent overturning or damage to the transmission system due to excessive braking when the vehicle speed is too high. When this parameter is set to Disabled, there is no additional auxiliary procedure for the drag brake rate.
- Drag Brake Rate**
It's the rate at which the drag brake increases to the preset value. This feature slows down how rapidly the ESC applies the drag brakes. Lower values are slower and prevent sudden stops or jerky stopping movements. You can choose the drag brake rate from level 1 (very soft) to level 15 (very aggressive).
- Turbo Timing**
This item is adjustable from 0 degree to 24 degrees, the corresponding turbo timing (you set) will initiate at full throttle. It's usually activated on long straightaway and makes the motor unleash its maximum potential. Turbo timing adds "RPM" at full throttle.
- Turbo Delay**
When "TURBO DELAY" is set to "INSTANT", the Turbo Timing will be activated when throttle trigger is moved to the full throttle position. When other value is applied, you will need to hold the throttle trigger at the full throttle position (as you set) till the Turbo Timing initiates.
- AUX3 CH Function**
This parameter is used to set the real-time adjustment parameters for the idle channel of the transmitter. First, plug a single white signal cable from the esc into an idle channel of the receiver, and then set the parameter you want to adjust in real time for this idle channel. This way, you can use the button/knob on the transmitter corresponding to this idle channel to set this parameter in real time. For example, the default parameter is the item 15 "Drag Brake Force", which means that the button/knob on the transmitter corresponding to the channel connected to a single white signal cable can be used to adjust the drag brake force in real time. You can set other parameters that you want to adjust in real time using the transmitter through the mobile app.
- AUX4 CH Function**
The function of this parameter is the same as the previous one (item 20), and it is also used to set the real-time adjustment parameters for the idle channel of the transmitter. First, plug a single yellow signal cable from the esc into an idle channel of the receiver, and then set the parameter you want to adjust in real time for this idle channel. The default parameter is the item 17 "Drag Brake Rate", you can set other parameters that you want to adjust in real time using the transmitter through the mobile app.

4 ESC Programming & Firmware Upgrade - The Axe ESC is Only Adjustable using the HW Link App and a Bluetooth enabled Smart Phone

- Program your ESC with a smart phone (installed with the HW LINK V2 app)**
• Download and install the Hobbywing's official app "HW LINK V2" on your smart phone. For smart phones with the iOS operating system, please search "Hobbywing" in the App Store; for smart phones with the Android operating system, search "Hobbywing" in the Google Play or download it from our website (https://www.hobbywing.com).
• Connect a battery to the ESC and turn it on, then open the Hobbywing official app "HW LINK V2" on your smart phone. It will ask if you want to connect "Bluetooth" or "WiFi" the first time when you open the app; at this point, please select "Bluetooth". You need to change the connection to "Bluetooth" after using the "WiFi" connection, you can click "Settings" (on the home page) and then "Select the connecting mode" to change the connection.
• A list of Bluetooth devices will pop out when you click the ESC icon on the upper right corner, then select the ESC you want to program to establish the Bluetooth connection between the ESC and smart phone. (Note: the default name and password of the Bluetooth device are HW_BLE**** & 888888 respectively).
• ESC Setup: Click [Parameters] on the home page to adjust the ESC parameters, click the ESC icon on the upper right corner to disconnect the Bluetooth connection between the ESC and smart phone after completing and saving the settings.
• Firmware Updating: Click [Firmware Update] and then select the [Available Version] to select the firmware version you need, and then click "Update" to upgrade your ESC.
• Data Logging: Click on the [Data Log] on the homepage of the APP, then you can choose to view the peak data or real-time data.

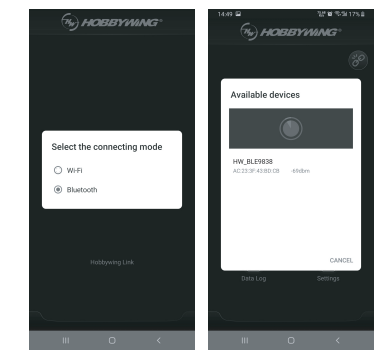

5 Factory Reset

- Restore the default values (only the ESC parameters) with a smart phone (installed with the HW LINK app): After entering the app and establishing the Bluetooth connection between the ESC and smart phone, click "Factory Reset" in "Parameters" to factory reset your ESC. After that, please re-calibrate the throttle range.
- Use the switch button to restore the factory Bluetooth name and password: Connect the esc to the battery and the esc is in the off state, press and hold the factory button for about 16 seconds. The RED LED in the switch will flash first, then the GREEN LED flashes, until both the RED and GREEN LEDs flash together, indicating that the factory Bluetooth name and password have been successfully restored, release the button, and the esc will automatically restart. The default factory name for Bluetooth is: HW_BLE * * * * and the default password is 888888.

6 Automatic Motor Pairing (should be run when there is any drive-ability issue)

- You must do the "automatic motor pairing" (as explained below) when any of the following situations occurs:
- Updated the ESC firmware.
 - Issues like loose rear endplate, severe impact, or abnormal heat (during the operation) abnormal power output occurs to the motor.
- Steps of "Automatic Motor Pairing":**
- Unplug the throttle wire from the receiver, and then remove the pinion gear;
 - Connect the esc to the battery and the esc is in the off state, press and hold the button on the power switch, the red light will flash first, then switch to green light flashing after about 8 seconds, and you can release the button. The motor will automatically run and wait for the motor to stop running. The red light on the switch will remain on, indicating completion of pairing.
 - Connect the throttle cable to the receiver and restart the esc to operate normally.

07 Explanations for Different Status LEDs

- During the Starting-up Process**
• The Red LED keeps flashing indicating the ESC doesn't detect any throttle signal or the neutral throttle value stored on your ESC may be different from the current value stored on the transmitter. - Redo the ESC calibration Process if your ESC is flashing and not working.
• The Green LED flashes "N (number of)" times indicating the number of LiPo cells you have plugged in.
- In Operation - What lights you should see.**
• The RED-GREEN LEDs are off when the throttle trigger is in the neutral position.
• The GREEN LED flashes when your vehicle runs forward. The Green LED will come on solid when pulling the throttle trigger to the full (100%) throttle endpoint and setting the "Max. Forward Force" to 100%.
• The GREEN LED flashes when you reverse the vehicle, the Green LED will come on solid when pushing the throttle trigger to the full reverse endpoint and setting the "Max. Reverse Force" to 100%.
- Error or Warning LED Codes**
• The Red LED flashes a short, single flash that repeats (→, →, →) indicating the low voltage cutoff protection is activated.
• The Green LED flashes a short, single flash that repeats (→, →, →) indicating the ESC thermal protection is activated.
• The Green LED flashes a short, double flash that repeats (→, →, →, →, →) indicating the motor thermal protection is activated.
• The Green and Red LEDs flash at the same time indicating the power system stops functioning due to "sensor issue". In that case, please check if the ESC sensor wire has been firmly connected to the motor sensor wire before resuming the operation.

08 Trouble Shooting

Trouble(s)	Possible Causes	Solution(s)
The ESC was unable to start the status LED, the motor after it was powered on.	1. No power was supplied to the ESC. 2. The ESC switch was damaged.	1. Check if all ESC & battery joints or connections have been well soldered or firmly connected. 2. Replace the switch.
The ESC was unable to start the motor but beeped "B-B, B-B" (the time interval was 1s) and the Green LED on the ESC flashed.	The battery voltage was beyond the normal range.	Check if the battery voltage is within the regulated range.
After the ESC was powered on and finished LiPo detection, the GREEN LED flashed N times, and then the RED LED flashed.	1. The ESC didn't detect any throttle signals. 2. The neutral throttle value stored on your ESC is different from the one stored on the transmitter.	1. Check if the throttle wire is reversely plugged in or in the wrong channel and if the transmitter is turned on. 2. Re-calibrate the throttle range.
The vehicle is going in the reversed direction.	The default motor direction didn't match the chassis.	Set the motor direction/rotation to the other option via the HW LINK app.
The motor suddenly stopped or significantly reduced the output in operation.	1. The receiver was influenced by some foreign interference. 2. The ESC entered the LVC protection. 3. The ESC entered the ESC thermal protection. 4. The motor entered the ESC thermal protection.	1. Check all devices and try to find out the possible causes, and check the transmitter's battery voltage. 2. The Red LED keeps flashing indicating the LVC protection is activated, please replace the battery. 3. The Green LED keeps flashing indicating the ESC thermal protection is activated. Please let it cool again before using the ESC again. 4. It is over temperature protection of motor if green light flashes continuously (double flash). Please continue to use it after the temperature of motor reduces.
The vehicle couldn't be started or stopped halfway, and the Red & Green LEDs flashes at the same time.	1. "Sensor wire connection" issue. 2. ESC problem.	1. Check if the ESC & motor sensor wires are damaged and re-connect them and re-start the ESC after confirming that there is no sensor issue. 2. Contact the dealer for customer service.
The car ran forward/backward slowly when the throttle trigger was at the neutral position.	1. The neutral position on the transmitter was not stable. 2. The ESC calibration was not proper.	1. Replace your transmitter. 2. Re-calibrate the throttle range or fine tune the neutral position on the transmitter.
The throttle travel setting could not be completed	The ESC did not receive the correct throttle signal	1. Check whether the throttle cable is correctly connected to the receiver. 2. If the servo works normally, you can connect the throttle cable of esc to the steering channel to have a test, or change the transmitter/receiver system for test directly.
The motor is very hot during running after upgrading firmware of ESC.	The ESC and motor didn't do "Automatic Motor Pairing"	Please make "Automatic Motor Pairing" according to the manual part 6.6.